



# Curriculum Guide 2023



**LONG BAY COLLEGE**

*Care, create, excel*

# GENERAL INFORMATION

The information in this guide is designed to help you carefully choose your subjects for 2023. The courses you select are crucial for your future, so it is important that you think carefully about your course direction. The further you go in the senior school, the more difficult it becomes to change that direction. That is why the best advice is to keep as broad a range of subjects for as long as possible.

## CONTENTS

<b>GENERAL INFORMATION</b>	<b>2</b>
<b>SELECTING YOUR LEARNING PROGRAMME FOR 2023</b>	<b>3</b>
<b>PEOPLE TO SEE FOR SUBJECT ADVICE</b>	<b>3</b>
<b>NATIONAL CERTIFICATE OF EDUCATIONAL ACHIEVEMENT</b>	<b>3</b>
<b>UNIVERSITY ENTRANCE</b>	<b>4</b>
<b>CAREERS</b>	<b>6</b>
<b>GATEWAY</b>	<b>6</b>
<b>YEAR LEVEL PROGRAMMES IN 2023</b>	<b>6</b>
<b>STUDENTS WITH ADDITIONAL LEARNING NEEDS</b>	<b>8</b>
<b>ENGLISH FOR ACADEMIC PURPOSES (EAP)</b>	<b>8</b>
<b>SCHOLARSHIP</b>	<b>9</b>
<b>COURSE DESCRIPTIONS</b>	<b>9</b>
<b>COURSES AVAILABLE</b>	<b>10</b>
<b>BUSINESS</b>	<b>12</b>
<b>ENGLISH</b>	<b>17</b>
<b>GLOBL STUDIES</b>	<b>21</b>
<b>GLOBAL STUDIES - LANGUAGES</b>	<b>21</b>
<b>GLOBAL STUDIES - ENGLISH FOR ACADEMIC PURPOSES</b>	<b>26</b>
<b>HEALTH &amp; PHYSICAL EDUCATION</b>	<b>29</b>
<b>MATHEMATICS</b>	<b>35</b>
<b>PERFORMING ARTS</b>	<b>39</b>
<b>SCIENCE</b>	<b>44</b>
<b>SOCIAL SCIENCES</b>	<b>50</b>
<b>TECHNOLOGY</b>	<b>58</b>
<b>VISUAL ARTS</b>	<b>67</b>
<b>END OF DOCUMENT – CLICK TO RETURN TO CONTENTS</b>	<b>72</b>

*Click on a title above to be taken to that section*

Version number	1.3
Last amended	27 July 2022

## SELECTING YOUR LEARNING PROGRAMME FOR 2023

There are recommended pathways, as prior experience of a subject is a strong indicator of future success. Note the progress of subjects from Year 11 through to Year 13 in the subject pathways. Some subjects are difficult to take up again if dropped early or may not go through to Year 13.

Students will be selecting their options for 2023 in Term 3 via the web portal. This will follow discussions with their Atawhai leader.

All students should consider the following for each course:

- ✓ Will I enjoy the course?
- ✓ Can I succeed at the subject?
- ✓ Where does it lead?

Senior students should also consider:

- ✓ What qualifications and future learning do my courses lead to
  - while at school?
  - once I've left?
- ✓ Does my learning programme help me meet the literacy and numeracy requirements
  - for NCEA?
  - for University Entrance?
- ✓ Do all my courses together give me enough credits or grades for the qualifications that I want?
- ✓ Do all my courses together make up a manageable workload for me?

## PEOPLE TO SEE FOR SUBJECT ADVICE

People you can see for advice about your course selection here at Long Bay College are your Atawhai leader, subject teachers and Deans.

Mrs Thomas ([KThomas@lbc.school.nz](mailto:KThomas@lbc.school.nz)), our Careers Counsellor, has information on a huge variety of careers and tertiary courses. She is available on 477 9009 ext 839 and is happy to talk with parents.

Students studying English for Academic Purposes (EAP) should also seek pathway advice from the Head of Global Studies, Mrs Victoria Yun ([vyun@lbc.school.nz](mailto:vyun@lbc.school.nz)).

## NATIONAL CERTIFICATE OF EDUCATIONAL ACHIEVEMENT

New Zealand's qualification for school learners is the National Certificate of Educational Achievement – NCEA. NCEA is a qualification on New Zealand's National Qualifications Framework (NQF).

- NCEA is achievement based. Standards have been set in each area of learning. When students achieve these standards, they earn credits towards their NCEA qualification.
- The NQF contains assessment standards: Credits from all achievement standards and unit standards count towards NCEA.
- Achievement standards (AS) allow students to show the quality of their achievement in a standard – students can just achieve the standard, or achieve it with Merit or with Excellence.
- Unit standards (US), enable students to either achieve the standard by meeting the criteria or not achieve the standard. There are no merit or excellence grades.
- Some standards are assessed in school during the year (internally); other achievement standards are assessed externally, usually in end-of-year exams.
- All unit standards are internally assessed.

---

## NCEA RESULTS

In January, the New Zealand Qualifications Authority (NZQA) issues students with a full profile of their achievement in each subject on their online platform. This interim results notice shows:

- The student's credits and grades for each standard.
- Endorsements (course or certificate level).
- NZQA will also provide each student with a record of achievement which summarises all standards, credits and qualifications gained to date.

NCEA candidates can access personal performance information themselves via <https://www.nzqa.govt.nz/login/> using their NZQA learner log in.

---

## HOW DO STUDENTS COMPLETE A QUALIFICATION?

**There are three NCEA qualifications. The requirements for each level are shown below:**

**Level 1** - 80 credits from any level (including 10 literacy and 10 numeracy credits).

**Level 2** - 80 credits, with at least 60 credits from Level 2 or above (including 10 literacy and 10 numeracy credits from Level 1).

**Level 3** - 80 credits, with at least 60 credits from Level 3 or above (including 10 literacy and 10 numeracy credits from Level 1).

*Once the 10 literacy and 10 numeracy credit requirement has been completed it will count towards subsequent levels.*

---

## NCEA LEVEL 1-3 CERTIFICATE ENDORSEMENTS

Students can achieve their certificate with Merit or Excellence endorsement. The requirements for the qualification must also be met.

**Endorsement with Merit:** 50 credits at Merit or Excellence at the same level or higher.

**Endorsement with Excellence:** 50 credits at Excellence at the same level or higher.

Credits counting towards endorsement may be gained over more than one year and more than one level, but must be gained at the level of the certificate or above. For example, Level 2 credits will count towards endorsement of a Level 1 NCEA, but Level 1 credits will not count towards endorsement of a Level 2 NCEA.

---

## NCEA LEVEL 1-3 COURSE ENDORSEMENT

To attain a course endorsement a student will need to achieve 14 or more credits at Merit and Excellence level with at least 3 credits from externally assessed standards and 3 credits from internally assessed standards in a single course in a single year. This endorsement will be recorded on the students Result Notice.

# UNIVERSITY ENTRANCE

Students who want to study at university must ensure that the courses they select at school allow them to qualify for university entry. You will be qualified for entrance to a university in New Zealand in 2023 if you have obtained all of the following:

- NCEA Level 3 – 80 credits (including minimum of 60 Level 3 credits with remaining 20 credits from Level 2 or above).
- Level 3 approved subjects – At least 14 credits in each of three Level 3 university approved subjects.
- Literacy – At least 10 credits at Level 2 or higher in English or Te Reo Māori or Level 4 English for Academic Purposes (EAP) or from other approved standards; 5 credits must be in reading and 5 credits must be in writing. Course descriptions use R for reading, W for writing, B for credits that can count as either reading or writing.
- Numeracy – At least 10 credits at Level 1 or higher from relevant standards.

---

## ENTRY REQUIREMENTS FOR UNIVERSITY COURSES

The entry criteria for any tertiary course should be checked with the university – the same course at different universities can have different entry criteria.

University Entrance will NOT give you entrance into all universities and/or all courses (UE is necessary but many courses and/or universities require more). Therefore, students should be gaining 80 Level 3 credits from university approved subjects.

Students intending to apply for:

- University of Auckland should have FIVE university approved subjects. This should include 17 English credits at Level 2 or Level 3 (or students will need to do a compulsory Academic English paper at university). This differs from the UE literacy requirement and must come from taking Level 2/Level 3 English or Level 2/Level 3 English Enrichment. Students studying English for Academic Purposes (EAP) should also seek advice from their EAP teachers on how they can meet requirements for University of Auckland.
- All other universities, should have a minimum of FOUR university approved subjects in their programme, however, five is preferable.

Some courses require a specific Rank Score. This is calculated as follows:

- Take your top 80 Level 3 credits.
- For each Excellence apply 4 points.
- each Merit apply 3 points.
- each Achieved apply 2 points.
- Use credits from 5 or fewer university approved subjects only.
- Use a maximum of 24 credits per subject.

Subject	Excellence credits	Merit credits	Achieved credits
English	8	6	10
History	-	6	16
Statistics	4	4	16
Geography	-	10	7
French	-	-	24
<b>Subtotals</b>	<b>12</b>	<b>26</b>	<b>73</b>
<b>Best 80 credits</b>	<b>12</b>	<b>26</b>	<b>42</b>
(only up to 80 credits in total)			
<b>Calculate points</b>	<b>48 points (12x4)</b>	<b>78 points (26x3)</b>	<b>84 points (42x2)</b>

This example has a rank score of 210 points  
(48 + 78 + 84)

The University of Auckland has a rank score calculator - <https://www.rankscorecalculator.auckland.ac.nz/>

The following are examples of the current requirements for NZ universities. These are subject to change and students should check the relevant university website for up-to-date information. Please be aware that this can change at any time.

University	Requirement/recommendation	Website	
<b>The University of Auckland</b>	Arts	150 points	<a href="https://www.auckland.ac.nz/">https://www.auckland.ac.nz/</a>
	Science	165 points	
	Commerce	180 points	
	Bio-medical Science	280 points	
	Engineering	260 points (Physics/Calculus externals)	
<b>AUT</b>	UE, but check specific requirements for each course - AUT has higher guaranteed scores.	<a href="https://www.aut.ac.nz/">https://www.aut.ac.nz/</a>	
<b>University of Canterbury</b>	UE (but check special degree requirements)	<a href="https://www.canterbury.ac.nz/">https://www.canterbury.ac.nz/</a>	
<b>Massey University</b>	140 points (preferred)	<a href="http://www.massey.ac.nz/">http://www.massey.ac.nz/</a>	
<b>University of Otago</b>	140 points (preferred)	<a href="https://www.otago.ac.nz/">https://www.otago.ac.nz/</a>	
<b>The University of Waikato</b>	UE but look for extra criteria	<a href="https://www.waikato.ac.nz/">https://www.waikato.ac.nz/</a>	
<b>Victoria University of Wellington</b>	150 points Architecture and Building Science (180 points)	<a href="https://www.victoria.ac.nz/">https://www.victoria.ac.nz/</a>	
<b>UNITEC</b>	UE for some courses; check each course for subject requirements	<a href="https://www.unitec.ac.nz/">https://www.unitec.ac.nz/</a>	

## CAREERS

Careers Guidance and Counselling is available to students, who can make appointments to see the Careers Advisor. Our Careers Room has a wide range of information available. During the year, students can attend university liaison visits, trade ITO visits, lunchtime presentations, the Careers Expo, and STAR and Gateway courses as well as participating in a number of out-of-school trips and attending a wide variety of open days and information sessions. Students at risk of leaving school unprepared for the workplace or future education/training will be identified by teachers, Deans and the Guidance Counsellors and referred to the Careers Advisor. Students leaving school have their career plans checked by the Careers Advisor before a Leavers Form is issued.

## GATEWAY

The Gateway programme assists students to transition from school into work or a tertiary course. Students are given the opportunity to work in a structured workplace environment 1 day per week for 5-10 weeks in an industry of their choice. The programme allows students to explore the practical aspects of specific career options and gives them the opportunity to gain new skills and knowledge. As part of the course, students will complete First Aid, OSH and Interview Skills courses which will give them 20 Level 2 and Level 3 credits.

## YEAR LEVEL PROGRAMMES IN 2023

### ASPIRING SCHOLARS

A programme supportive of academically excellent students and their engagement with our Junior Curriculum. It is not a “gifted” programme but one with academic extension and enrichment that will be of benefit to gifted students as well. It is a programme that covers five junior curriculum classes within the same class grouping and is supportive of students in working toward NZQA Scholarship as they work through Years 9 to 13.

Being selected for the Aspiring Scholars programme is not seen as a reward but as a response to an educational need. Students selected have the right to choose not to enter the programme, without repercussions. Students not initially selected, who indicate through high performance the ability required, will be offered the opportunity to move into the programme in Year 10. Where appropriate the programme provides curriculum enrichment and encourages differentiated tasks.

Entry to our Aspiring Scholars Programme in Year 9 is determined by identification in the enrolment process, feedback from prior school, educational psychologist report (if evident), performance in entrance testing and prior scholastic performance.

### ACCELERATION COURSES

Junior students identified as likely to benefit from acceleration in English and Maths are targeted for additional timetabled support for a semester.

This acceleration occurs through targeted classes running in parallel to their timetabled English or Maths class. Entrance to the class determined in Semester 1 in Year 9 by identification in the enrolment process, feedback from prior school, educational psychologist report (if evident), performance in entrance testing and prior scholastic performance. Subsequent entry is based on the feedback of classroom teachers, a student's progress to date and in discussion with the Heads of Maths and English. If a student's family are interested in being considered for Junior Acceleration Courses, they should identify this in the enrolment process.

\*Please note that all new entrant student testing data is reviewed and where the College perceives a student would benefit from engaging with Junior Acceleration Courses further discussion with parents will occur ahead of a potential placing in our course.



---

## YEAR 9

All Year 9 students study core subjects English, Mathematics, Science, Social Science and Health & Physical Education.

In addition, students will choose four modules. One module must come from each table.

Modules run for ONE semester. There are two semesters in each academic year.

Table A	Table B	Table C
<ul style="list-style-type: none"><li>• Art</li><li>• Contemporary Music</li><li>• Dance</li><li>• Digital Art</li><li>• Drama</li><li>• Performance Music</li></ul>	<ul style="list-style-type: none"><li>• Design &amp; Technology</li><li>• Design &amp; Visual Communication</li><li>• Digital Technology Studies</li><li>• Food Technology</li></ul>	<ul style="list-style-type: none"><li>• Global Studies – Asian Language</li><li>• Global Studies – European Language</li><li>• Te Reo Māori Studies</li><li>• Media Studies</li><li>• Sales &amp; Marketing</li><li>• Sports Science &amp; Athletic Development</li></ul>

---

## YEAR 10

All Year 10 students study core subjects English, Mathematics, Science, Social Science and Health & Physical Education

In addition, students will choose four modules. One module must come from each table.

Modules run for ONE semester. There are two semesters in each academic year.

Table A	Table B	Table C
<ul style="list-style-type: none"><li>• Art</li><li>• Contemporary Music</li><li>• Dance</li><li>• Digital Art</li><li>• Drama</li><li>• Performance Music</li></ul>	<ul style="list-style-type: none"><li>• Design &amp; Visual Communication</li><li>• Design &amp; Technology</li><li>• Digital Technology Studies</li><li>• Food Technology</li></ul>	<ul style="list-style-type: none"><li>• Commerce</li><li>• Global Studies – Asian Language</li><li>• Global Studies – European Language</li><li>• Te Reo Māori</li><li>• Media Studies</li><li>• Sports Science &amp; Athletic Development</li></ul>

## YEAR 9 & 10 PROJECTS

In Term 4 2023, Year 9 and Year 10 students at Long Bay College will be engaged in Projects.

The students will have the opportunity to develop their own learning and explore and engage with topics that go beyond the limits of the New Zealand Curriculum. Students made subject choices relating to Projects in Term 2.

---

## YEAR 11

Students study six Level 1 NCEA subjects including English and Mathematics. Studying a Science subject is highly recommended. Students should aim for a broad range of subjects and avoid taking more than two from one faculty.

It is recommended that students select a manageable group of subjects. Selecting six 24-credit courses may result in too big a workload for some students.

A maximum of two portfolio subjects is strongly recommended. Portfolio subjects are indicated with an  $\lambda$  in the subject title.

---

## YEAR 12

Students study six NCEA subjects. Studying English is strongly recommended, especially for those who may be considering university.

There are situations where students may be studying at more than one level. If choosing portfolio subjects, students are recommended to choose a maximum of two. Portfolio subjects are indicated with an  $\lambda$  in the subject title.

---

## YEAR 13

Students intending to study at university should read the [UNIVERSITY ENTRANCE](#) section of this guide and check that their chosen subjects will enable them to meet the recommended entry requirements.

Students studying a mix of Level 1, 2, and 3 subjects are working towards the NCEA qualification at the appropriate level for them. If choosing portfolio subjects, students are recommended to choose a maximum of two (Portfolio subjects are indicated with an  $\lambda$  in the subject title).

## STUDENTS WITH ADDITIONAL LEARNING NEEDS

Learning Support offers two programmes as an alternative to NCEA.

---

### NEW ZEALAND CERTIFICATE IN SKILLS FOR LIVING FOR SUPPORTED LEARNERS

This is a NZQA approved programme for students working at the beginning of the NZ Curriculum and who are unable to access and experience success in the NCEA system. The programme provides real opportunities for inclusion and personalized learning based on a student's strengths and interests. There is a focus on developing confidence, personal growth, self-esteem and independence.

Students (Years 9 to 13) will work for two to four years on this programme, depending on their learning needs and will work towards achieving credits in both Literacy and Numeracy.

---

### LIFE SKILLS PROGRAMME

This programme is for students who are not currently reaching their full potential and are struggling with a full NCEA programme. It offers a flexible framework that gives students the opportunity to achieve Communication Skills and Core Generic unit standards. Within the programme there are opportunities to use literacy and numeracy skills to organise, interpret and communicate information in a way which relates to and can be applied to real-life scenarios.

Students (Years 11 to 13) will work on this programme for 18 months to two years, depending on their learning needs. Successful completion of this programme may lead on to New Zealand Certificate in Foundation Skills Level 2 Qualification; NCEA Level 2; employment or vocational training/apprenticeships.

---

### SPECIAL ASSESSMENT CONDITIONS

Learning Support also supports students with Special Assessment Conditions (SAC), through making Special Assessment Condition applications to NZQA, providing advice to teachers and students, and providing SAC for some assessments.

Please contact Kristen (Krick) Evans, Head of Learning Support Faculty and SENCo: [KEvans@lbc.school.nz](mailto:KEvans@lbc.school.nz) for further information.

## ENGLISH FOR ACADEMIC PURPOSES (EAP)

Long Bay College provides cutting-edge courses for all English language learners, based on individual needs and chosen pathways.

Effective and relevant programmes help students to become confident and proficient in English. By studying at Long Bay College, students are not only supported in everyday life in New Zealand, but are also able to access the entire curriculum at the school and be successful in their academic studies.

EAP courses have been carefully designed to provide the framework for language learning, as well as the skills required to achieve at NCEA. All levels of English are catered for, from Beginners to Advanced. Many courses are also NCEA accredited and provide a pathway to University Entrance literacy.

All students will be assessed for English levels on arrival. Progress will then be carefully monitored, and the EAP teacher, along with the Head of EAP, will regularly review language levels.

All EAP classes are taught in a positive, inclusive learning environment.

The English for Academic Purposes curriculum is designed to assist students in acquiring the language skills they need to function effectively in a highly literate, often multi-lingual society.

Please see [English for Academic Purposes](#) (EAP) in the Global Studies section of this guide. This is the most relevant and effective pathway for English language learners.



## SCHOLARSHIP

NZQA Scholarship is the premier academic award a secondary school student in New Zealand can achieve. It is separate to NCEA Levels 1, 2 or 3. Programmes and tutorials outside of class support students working towards NZQA Scholarship exams. For more information about Scholarship subjects, please see our Scholarship prospectus.

## COURSE DESCRIPTIONS

The courses are grouped in learning areas. For each course, you need to check:

- The course which it follows on from.
- Where the subject leads to.
- The number and type of credits offered.

Each learning area will include a pathway chart and descriptions of the courses. The descriptions include:

- An outline of the course.
- The number of credits available (int = internally assessed, ext = externally assessed).
- The contribution to Level 1 literacy, numeracy or University Entrance literacy (R = reading, W = writing, B = can count as either reading or writing).
- Whether an endorsement is possible for the course.
- The staff member in charge of the course.

Pathway charts show:

- Lines between subjects indicate recommended pathways.
- Prior experience and success in a subject is a strong predictor of future success.
- If a student is likely to study a subject in later levels early specialisation is recommended.

## COURSES AVAILABLE

Some subjects stop at Level 1, some at Level 2 and some lead into two or three other subjects. Compulsory courses are in **BOLD**. Courses in CAPITALS are full year, *others* are one semester. Senior courses are (or lead to) university approved courses unless they are UNDERLINED. Courses that are in *ITALICS* are taught twice per week after school.

	Year 9	Year 10	Year 11	Year 12	Year 13
Business	Sales and Marketing	Commerce	ACCOUNTING BUSINESS STUDIES ECONOMICS ACCOUNTING AND ECONOMICS TRANSITION (English language learners)	ACCOUNTING BUSINESS STUDIES or BUSINESS STUDIES EXTENSION ECONOMICS	ACCOUNTING BUSINESS STUDIES or BUSINESS STUDIES EXTENSION ECONOMICS
English	<b>ENGLISH</b> Targeted Literacy	<b>ENGLISH</b> Targeted Literacy	<b>ENGLISH</b> or <b>ENGLISH ENRICHMENT</b> or <u>ENGLISH FOR LITERACY</u>	ENGLISH or ENGLISH ENRICHMENT or <u>ENGLISH FOR LITERACY</u>	ENGLISH or ENGLISH ENRICHMENT or <u>ENGLISH FOR LITERACY</u>
Global Studies (Languages)	Global Studies – Asian Language Global Studies - European Language Te Reo Māori	Global Studies – Asian Language Global Studies - European Language Te Reo Māori	GLOBALS STUDIES: ASIAN LANGUAGES GLOBALS STUDIES: EUROPEAN LANGUAGES TE REO MĀORI	CHINESE TE REO MĀORI <i>CHINESE FOR NATIVE SPEAKERS</i>	CHINESE TE REO MĀORI <i>CHINESE FOR NATIVE SPEAKERS</i> <i>LANGUAGES FOR NATIVE SPEAKERS</i>
Global Studies (English for Academic Purposes)	<b>GLOBAL STUDIES WITH ENGLISH FOR ACADEMIC PURPOSES</b> (English language learners)  RECEPTION ENGLISH FOR ACADEMIC PURPOSES (English language learners)	<b>GLOBAL STUDIES WITH ENGLISH FOR ACADEMIC PURPOSES</b> (English language learners)	<u>ENGLISH FOR ACADEMIC PURPOSES (EAP)</u> (English language learners)	<u>ENGLISH FOR ACADEMIC PURPOSES (EAP)</u> (English language learners)	<u>ENGLISH FOR ACADEMIC PURPOSES (EAP)</u> (English language learners)  <u>ENGLISH FOR ACADEMIC FOUNDATION (EAL)</u> (English language learners foundation studies)  <u>IELTS PREPARATION COURSE</u>
Health and Physical Education	<b>HEALTH AND PHYSICAL EDUCATION</b>  Sports Science and Athletic Development	<b>HEALTH AND PHYSICAL EDUCATION</b>  Sports Science and Athletic Development	HEALTH PHYSICAL EDUCATION  HEALTH AND PHYSICAL EDUCATION	HEALTH PHYSICAL EDUCATION  <u>EARLY CHILDHOOD EDUCATION</u>  <u>PRACTICAL PHYSICAL EDUCATION AND SPORTS LEADERSHIP</u>	HEALTH PHYSICAL EDUCATION  <u>EARLY CHILDHOOD EDUCATION</u>  <u>PRACTICAL PHYSICAL EDUCATION AND SPORTS LEADERSHIP</u>  <u>FITNESS STUDIES</u>

<b>Mathematics</b>	<b>MATHEMATICS</b> Targeted Numeracy	<b>MATHEMATICS</b> <b>or MATHEMATICS ENRICHMENT</b> Targeted Numeracy	<b>MATHEMATICS</b> <b>or MATHEMATICS ENRICHMENT</b> MATHEMATICS TRANSITION (English language learners)	MATHEMATICS STATISTICS CALCULUS	MATHEMATICS STATISTICS CALCULUS
<b>Performing Arts</b>	Dance Drama Contemporary Music Performance Music	Dance Drama Contemporary Music Performance Music	DANCE DRAMA MUSIC	DANCE DRAMA MUSIC	DANCE DRAMA MUSIC
<b>Science</b>	<b>SCIENCE</b>	<b>SCIENCE</b>	BIOLOGY CHEMISTRY EARTH AND SPACE SCIENCE PHYSICS <u>GENERAL SCIENCE</u> SCIENCE TRANSITION (English language learners)	BIOLOGY CHEMISTRY EARTH AND SPACE SCIENCE PHYSICS	BIOLOGY CHEMISTRY EARTH AND SPACE SCIENCE PHYSICS
<b>Social Science</b>	<b>SOCIAL SCIENCE</b> Media Studies	<b>SOCIAL SCIENCE</b> Media Studies	GEOGRAPHY HISTORY MEDIA STUDIES	ART HISTORY CLASSICS GEOGRAPHY HISTORY MEDIA STUDIES PSYCHOLOGY <u>TOURISM</u>	ART HISTORY CLASSICS GEOGRAPHY HISTORY MEDIA STUDIES PSYCHOLOGY <u>TOURISM</u>
<b>Technology</b>	Design and Visual Communication Digital Technology Studies Food Technology Design and Technology	Design and Visual Communication Digital Technology Studies Food Technology Design and Technology Foundation Technology (English language learners)	DESIGN AND VISUAL COMMUNICATION <sup>λ</sup> DIGITAL TECHNOLOGY STUDIES DESIGN AND TECHNOLOGY <sup>λ</sup> <u>ENGINEERING</u> <u>CUISINE AND HOSPITALITY STUDIES</u> <u>WOOD TECHNOLOGY</u>	DESIGN AND VISUAL COMMUNICATION <sup>λ</sup> DIGITAL TECHNOLOGY STUDIES DESIGN AND TECHNOLOGY <sup>λ</sup> <u>ENGINEERING</u> <u>CUISINE AND HOSPITALITY STUDIES</u> <u>WOOD TECHNOLOGY</u>	DESIGN AND VISUAL COMMUNICATION <sup>λ</sup> DIGITAL TECHNOLOGY STUDIES DESIGN AND TECHNOLOGY <sup>λ</sup> <u>ENGINEERING</u> <u>CUISINE AND HOSPITALITY STUDIES</u> <u>WOOD TECHNOLOGY</u>
<b>Visual Arts</b>	Art Digital Art	Art Digital Art	ART <sup>λ</sup> DIGITAL ART <sup>λ</sup> * <small>* Students can only study either NCEA Level 1 Art or NCEA Level 1 Digital Art</small>	ART HISTORY DESIGN <sup>λ</sup> PAINTING <sup>λ</sup> PHOTOGRAPHY <sup>λ</sup>	ART HISTORY DESIGN <sup>λ</sup> PAINTING <sup>λ</sup> PHOTOGRAPHY <sup>λ</sup>

<sup>λ</sup> Portfolio subjects are indicated with this symbol <sup>λ</sup>. If choosing portfolio subjects, students are recommended to choose a maximum of two.

All courses offered will be run subject to student numbers and staffing availability at the Principal's discretion.

# BUSINESS

Head of Faculty – Mrs Sonia Collins

Ext 862

[scollins@lbc.school.nz](mailto:scollins@lbc.school.nz)

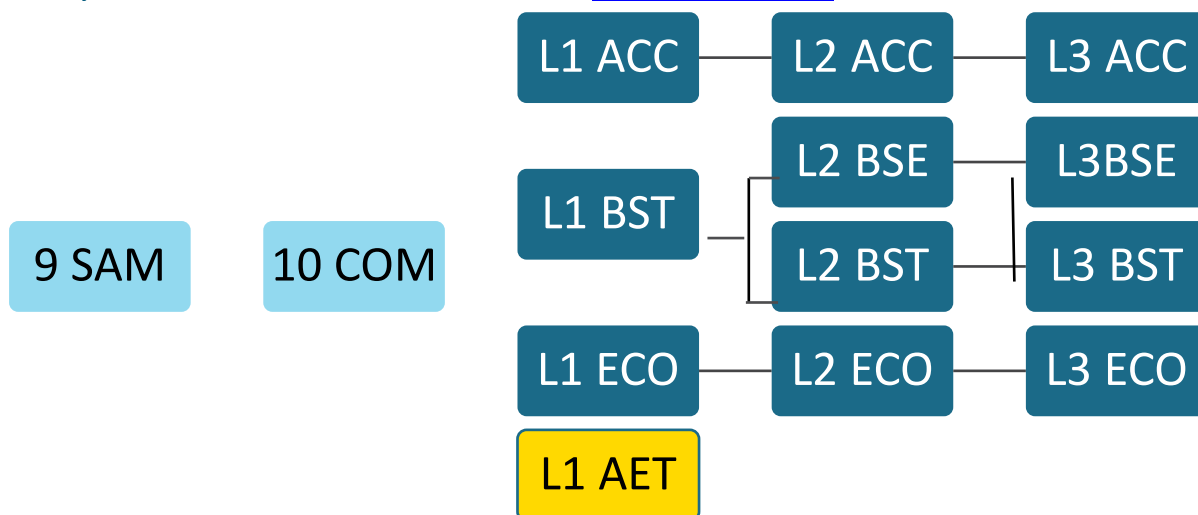

## Y9 SALES AND MARKETING (9SAM)

*This course leads to 10COM*

The course challenges students to think about different aspects of marketing, and how this influences how a business might make decisions about their product development, or their advertising. During the course students will also have the opportunity to design a product and develop their own skills using print and on-line or film media to advertise their product.

Teacher in charge - Mrs Sonia Collins

## Y10 COMMERCE (10COM)

*This course leads to L1ACC, L1BST, L1ECO*

This course aims to develop students financial capability and gain some knowledge and skills in Accounting, Business and Economics. The emphasis at this level is on individual students, their whanau and small business. It will enable students to understand how the individual makes economic and financial decisions. It is aimed at helping them gain the skills needed to manage their personal limited means. This will allow students to participate more effectively in their daily lives as consumers and workers. Students will learn basic accounting concepts, how households behave in a collective way and discover that enterprise and entrepreneurship exist in many forms in their own community.

Teacher in charge - Mrs Sonia Collins

## L1 ACCOUNTING & ECONOMICS TRANSITION (L1AET)

*This course leads to L2ACC, L2BST, L2ECO*

This course is designed for English language learners. It develops a student's understanding of how the individual makes economic and financial decisions. It is aimed at helping them gain the skills needed to manage their personal limited means; understand economic terminology; supply and demand; basic accounting concepts; and the preparation of financial statements. This transition course helps to develop a student's use of business language and apply it in business settings. It provides a pathway for Accounting, Economics and Business Studies in our senior school and for future tertiary study. Students will attempt various achievement standards at NCEA level 1 according to their individual development.

Teacher in charge – Mrs Sonia Collins

## L1 ACCOUNTING (L1ACC)

*This course follows on from 10COM and leads to L2ACC*

This course gives students an understanding of the business world as it affects the individual. The aim is to provide students with knowledge and skills in Accounting. The skills learnt include the conceptual basis of accounting, processing financial transactions for a small entity, preparation and understanding of financial statements, making a financial decision and preparing financial information for a community organisation. This course will benefit students in any career they choose as well as in managing their own financial affairs.

Teacher in charge - Mrs Sonia Collins

### **Students in this course will be working towards**

12 credits that are internally assessed and 8 credits that are externally assessed

10 credits towards Level 1 Literacy

Course endorsement is possible in L1 Accounting

This course leads to a university approved course.

## L1 BUSINESS STUDIES (L1BST)

*This course follows on from 10COM and leads to L2BST, L2BSE*

This is a foundation course that will help students gain business knowledge and understand the way businesses operate. Students will gain real life experience carrying out a business. It will set students up for further study in Business.

Teacher in charge - Mrs Sonia Collins

### **Students in this course will be working towards**

12 credits that are internally assessed and 8 credits that are externally assessed

20 credits towards Level 1 Literacy

Course endorsement is possible in L1 Business Studies

This course leads to a university approved course.

## L1 ECONOMICS (L1ECO)

*This course follows on from 10COM and leads to L2ECO*

Whether it's scarcity (limited resources), opportunity cost (what must be given up obtaining something else), or equilibrium (the price at which demand equals supply), this course gives students a fluency in fundamental terms needed to understand how markets work. L1 Economics gives students tools that allow them to decode the consumers, producers and government's behaviour and enable students to make economically sound decisions.

Teacher in charge - Mrs Sonia Collins

### **Students in this course will be working towards**

8 credits that are internally assessed and 12 credits that are externally assessed

20 credits towards Level 1 Literacy

Course endorsement is possible in L1 Economics

This course leads to a university approved course.

## L2 ACCOUNTING (L2ACC)

*This course follows on from L1ACC and leads to L3ACC*

The aim of this course is to introduce students to manual and computer methods of recording accounting data and to provide them with a clear basic understanding of financial reports and their components. The course will assist students to understand the accounting principles and processes involved in designing an accounting system, accounting for cash, accounts receivable, accounts payable, inventory and property, plant and equipment. Students will prepare and analyse financial statements. This course will benefit students in any career they choose.

Teacher in charge - Mrs Sonia Collins

### **Students in this course will be working towards**

15 credits that are internally assessed and 4 credits that are externally assessed

10 credits towards Level 1 Literacy

19 credits towards Numeracy

Course endorsement is possible in L2 Accounting

This course leads to a university approved course.

## L2 BUSINESS STUDIES (L2BST)

*This course follows on from L1ACC, L1BST, L1ECO and leads to L3BST, L3BSE*

This course introduces students to the practical aspects of running their own business and being self-employed. They will experience first-hand what it is like to operate a business. The subject delivers both theory and academic content related to business (e.g. market research, motivation theory, budgeting) and the practical and technical skill sets, as well as interpersonal skill sets of working within a team, and running a business.

Teacher in charge - Mrs Sonia Collins

### **Students in this course will be working towards**

18 credits that are internally assessed and 0 credits that are externally assessed

15 credits towards Level 1 Literacy

3 credits towards Numeracy

Course endorsement is not possible in L2 Business Studies

This course leads to a university approved course.

## L2 BUSINESS STUDIES EXTENSION (L2BSE)

*This course follows on from L1ACC, L1BST, L1ECO and leads to L3BSE, L3BST*

This subject gives students a chance to learn and apply skills related to Business Studies. Students will look at the internal operations of a large business and how a large business responds to external factors. They will also undertake a practical investigation by running a social enterprise in the local community. The subject delivers both theory and academic content related to business e.g. market research and the practical and technical skill sets, as well as interpersonal skill sets of working within a team, and running a business. Additionally, students are stretched to apply their academic and theoretical understanding in the exams, as they need to apply their understanding in business situations, to produce realistic solutions in a business setting.

Teacher in charge - Mrs Sonia Collins

### **Students in this course will be working towards**

15 credits that are internally assessed and 4 credits that are externally assessed

19 credits towards Level 1 Literacy

Course endorsement is possible in L2 Business Studies Extension

This course leads to a university approved course.



## L2 ECONOMICS (L2ECO)

*This course follows on from L1ECO and leads to L3ECO*

Economics provides excellent insight into the real world. The course covers macroeconomics which plays a key role in all aspects of life and especially the politics part of the aggregate Aotearoa economy. Economics students will be well equipped with analytical and problem-solving skills, numerical and computer skills, as well as the ability to work well either alone or within a team. All of these skills are very transferable allowing students to branch into anything from stock investment, money exchange, business start-ups, to becoming a wise voter in the coming general election.

Teacher in charge - Mrs Sonia Collins

### Students in this course will be working towards

14 credits that are internally assessed and 6 credits that are externally assessed

20 credits towards Level 1 Literacy

10R, 8W credits to UE literacy (R/W/B)

Course endorsement is possible in L2 Economics

This course leads to a university approved course.

## L3 ACCOUNTING (L3ACC)

*This course follows on from L2ACC*

The aim of the course is to provide a foundation for the study of Accounting at University and other tertiary institutions. The course covers accounting for Partnerships, Companies and Manufacturing organisations. Students will develop their understanding of the conceptual basis of accounting, process transactions, prepare financial statements and explain information for management decision making. This course will benefit students in any career they choose.

Teacher in charge - Mrs Sonia Collins

### Students in this course will be working towards

13 credits that are internally assessed and 4 credits that are externally assessed

13 credits towards Level 1 Literacy

17 credits towards Numeracy

Course endorsement is possible in L3 Accounting

5B credits to UE literacy (R/W/B)

This course is university approved.

## L3 BUSINESS STUDIES (L3BST)

*This course follows on from L2BST, L2BSE*

This subject gives students a chance to learn and apply skills related to Business Studies. The highlight of this course is a practical business experience which sees students develop, outsource production, market, and sell an innovative and sustainable product. Students will gain valuable experience in leadership, business operations, human resource, finance and collaborating with others. The subject delivers both theory and academic content related to business and the practical and technical skill sets, as well as interpersonal skill sets of working within a team, and running a business. Students will also have the opportunity to analyse future proofing strategies to ensure long term viability of a business.

Teacher in charge - Mrs Sonia Collins

### Students in this course will be working towards

19 credits that are internally assessed and 0 credits that are externally assessed

19 credits towards Level 1 Literacy

19R credits to UE literacy (R/W/B)

Course endorsement is not possible in L3 Business Studies

This course is university approved.

### L3 BUSINESS STUDIES EXTENSION (L3BSE)

*This course follows on from L2BSE, L2BST*

During this course, students will investigate the global business environment and how businesses compete on the world stage. They will also undertake a complex business activity: developing, marketing, and producing a product for market (possibly through the YES Programme). The subject delivers both theory and academic content related to business (e.g. market research, report writing, understanding organisational issues) and the practical and technical skill sets, as well as interpersonal skill sets of working within a team, and running a business. Students of many diverse backgrounds enjoy the subject as it has wide ranging applications, and report that their learning feels tangible and immediately applicable.

Teacher in charge - Mrs Sonia Collins

#### **Students in this course will be working towards**

15 credits that are internally assessed and 4 credits that are externally assessed

19 credits towards Level 1 Literacy

15R, 4B credits to UE literacy (R/W/B)

Course endorsement is possible in L3 Business Studies Extension

This course is university approved.

### L3 ECONOMICS (L3ECO)

*This course follows on from L2ECO*

Economics is the perfect combination of numbers and words, problems, essays, calculations and interpretations. It is both an art and a science subject. Students will have the opportunity to learn and build microeconomic models which give insights into the real world, and then to critique these models on the basis of their assumptions. There is rarely a right answer in Economics but any argument put forward must be backed up by quantitative evidence. Students will ultimately enjoy Economics because it allows them to employ and develop analytical and evaluative skills.

Teacher in charge - Mrs Sonia Collins

#### **Students in this course will be working towards**

10 credits that are internally assessed and 10 credits that are externally assessed

20 credits towards Level 1 Literacy

10R, 10B credits to UE literacy (R/W/B)

Course endorsement is possible in L3 Economics

This course is university approved.

# ENGLISH

Head of Faculty - Mrs Jennie Taylor

Ext 867

[jtaylor@lbc.school.nz](mailto:jtaylor@lbc.school.nz)

The relevant and effective pathway for English language learners is English for Academic Purposes (EAP)

Please see the course descriptions in the [Global Studies](#) section of this guide.

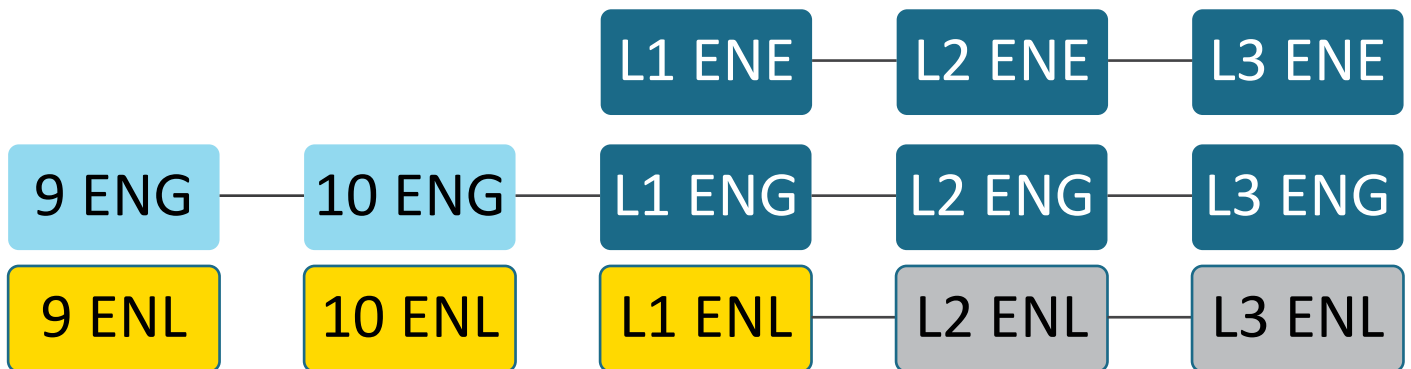

## Y9 ENGLISH (9ENG)

*This course leads to 10ENG*

Students will gain a deeper understanding of the English language by having a variety of opportunities for language to be used. There are two broad language streams: creating meaning and making meaning. The course itself will consist of comprehending a variety of texts, responding to texts, writing creatively and formally, presenting orally, using research skills and reading widely and independently. Grammar and spelling are emphasised.

Teacher in charge - Ms Jennie Taylor

## Y9 ENGLISH TARGETED (9ENL)

This course is in response to students' needs and teacher recommendations. This course offers additional literacy support to students who are struggling to achieve in mainstream classes.

Teacher in charge - Ms Jennie Taylor

## Y10 ENGLISH (10ENG)

*This course leads to L1ENE/L1ENG/L1ENL*

Students will gain a deeper understanding of the English language by having a variety of opportunities for language to be used. There are two broad language streams: creating meaning and making meaning. The course itself will consist of exploring a variety of texts, writing creatively and formally, presenting orally, using research skills and reading widely and independently. There is a focus on developing the skills needed for a high level of reading and writing competency. Specific language features and vocabulary are emphasised.

Teacher in charge - Ms Jennie Taylor

## Y10 ENGLISH TARGETED (10ENL)

This course is in response to students' needs and teacher recommendations. This course offers additional literacy support to students who are struggling to achieve in mainstream classes.

Teacher in charge - Ms Jennie Taylor

## L1 ENGLISH (L1ENG)

*This course follows on from 10ENG and leads to L2ENE/L2ENG/L2ENL*

This course supports students to develop their ability to use language skilfully and to interpret it effectively. Students will explore a range of written and visual texts. A focus is also on developing the ability to write in a variety of styles and for different audiences. This course will provide the English component of Level 1 NCEA and includes a combination of internal and external standards.

Teacher in charge - Ms Jennie Taylor

### **Students in this course will be working towards**

12 credits that are internally assessed and 4 credits that are externally assessed

16 credits towards Level 1 Literacy

Course endorsement is possible in L1 English

This course leads to a university approved course.

## L1 ENGLISH ENRICHMENT (L1ENE)

*This course follows on from 10ENG and leads to L2ENG/L2ENE*

This course challenges students to develop their ability to use language skilfully and to interpret it effectively while exploring a range of advanced literature. Students will study both written and visual texts. The course also focuses on developing the ability to write confidently in a variety of styles and for different audiences. This course will provide the English component of Level 1 NCEA and includes a combination of internal and external standards.

Teacher in charge - Ms Jennie Taylor

### **Students in this course will be working towards**

9 credits that are internally assessed and 8 credits that are externally assessed

17 credits towards Level 1 Literacy

Course endorsement is possible in L1 English

Enrichment

This course leads to a university approved course.

## L1 ENGLISH FOR LITERACY (L1ENL)

*This course follows on from 10ENG and leads to L2ENG/L2ENL*

This course will focus on the reading and writing skills necessary for competent, functional literacy in the future workplace and the wider world. Basic skills will be emphasised. This course will provide students with the opportunity to complete their NCEA Level 1 Literacy requirements.

Teacher in charge - Ms Jennie Taylor

### **Students in this course will be working towards**

19 credits that are internally assessed and 0 credits that are externally assessed

19 credits towards Level 1 Literacy

Course endorsement is not possible in L1 English for Literacy

This course can lead to a university approved course.

## L2 ENGLISH (L2ENG)

*This course follows on from L1ENE/L1ENG/L1ENL and leads to L3ENE/L3ENG/L3ENL*

This course will consist of a combination of internal and external standards. The course is aimed at students who enjoy and value the English language as an effective means of communication. Students will be challenged to read a range of texts, both written and visual, and to develop their skills in writing for different purposes. This is an academic course and students will be encouraged to aim high. Students will have the opportunity to gain their UE Literacy and will explore topics and texts that interest them.

Teacher in charge - Ms Jennie Taylor

**Students in this course will be working towards**

16 credits that are internally assessed and 4 credits that are externally assessed

Course endorsement is possible in L2 English

This course leads to a university approved course.

20 credits towards Level 1 Literacy

4R, 9W, 4B credits to UE literacy (R/W/B)

## L2 ENGLISH LITERATURE (L2ENE)

*This course follows on from L1ENE/L1ENG and leads to L3ENE/L3ENG*

This course will consist of a combination of internal and external standards. It is aimed at all students who enjoy experiencing texts that challenge and interest them. It is for students who love writing - in all forms. It will be strongly based on a wide range of literature and will focus on extending reading and writing skills. The course will provide the opportunity to gain UE Literacy.

Teacher in charge - Ms Jennie Taylor

**Students in this course will be working towards**

13 credits that are internally assessed and 8 credits that are externally assessed

Course endorsement is possible in L2 English Literature

This course leads to a university approved course.

21 credits towards Level 1 Literacy

4R, 10W, 4B credits to UE literacy (R/W/B)

## L2 ENGLISH FOR LITERACY (L2ENL)

*This course follows on from L1ENG/L1ENL and leads to L3ENL*

This Unit Standards course will focus on the reading and writing skills necessary for competent, functional literacy in the future workplace and the wider world. Basic skills will be emphasised. This course will provide students with the opportunity to work towards their NCEA Level 2 Literacy requirements. Individual Learning programmes are put in place to meet the needs of each student.

Teacher in charge - Ms Jennie Taylor

**Students in this course will be working towards**

25 credits that are internally assessed and 0 credits that are externally assessed

Course endorsement is not possible in L2 English for Literacy

This course does not lead to a university approved course.

7 credits towards Level 1 Literacy

### L3 ENGLISH (L3ENG)

*This course follows on from L2ENE/L2ENG*

This is an academically challenging course, aimed at students who enjoy and value the English language as an effective means of communication. Students will have the opportunity to explore a range of literature and film, while being encouraged to challenge themselves as readers and writers. Students will have the opportunity to gain their UE Literacy. Building academic reading and writing skills in preparation for post-secondary study is a large focus of this course.

Teacher in charge - Ms Jennie Taylor

**Students in this course will be working towards**

16 credits that are internally assessed and 4 credits that are externally assessed

Course endorsement is possible in L3 English

This course is university approved.

20 credits towards Level 1 Literacy

6W, 4B credits to UE literacy (R/W/B)

### L3 ENGLISH LITERATURE (L3ENE)

*This course follows on from L2ENE/L2ENG*

This course will consist of a combination of internal and external standards and is aimed at all students who enjoy experiencing texts that challenge and interest them. It is for students who love writing - in all forms. It will be strongly based on literary theory, a wide range of literature, and will focus on extending reading and writing skills. The course will provide the opportunity to gain UE Literacy.

Teacher in charge - Ms Jennie Taylor

**Students in this course will be working towards**

13 credits that are internally assessed and 8 credits that are externally assessed

Course endorsement is possible in L3 English Literature

This course is university approved.

21 credits towards Level 1 Literacy

4R, 6W, 8B, credits to UE literacy (R/W/B)

### L3 ENGLISH FOR LITERACY (13ENL)

*This course follows on from L2ENG/L2ENL*

This course will focus on the reading and writing skills necessary for competent, functional literacy in the future workplace and the wider world. Basic skills will be emphasised. This course will provide students with the opportunity to gain Level 3 credits while developing their communication skills.

Teacher in charge - Ms Jennie Taylor

**Students in this course will be working towards**

20 credits that are internally assessed and 0 credits that are externally assessed

Course endorsement is not possible in L3 English for Literacy

This course is not university approved.

3 credits towards Level 1 Literacy



# GLOBAL STUDIES

Head of Faculty – Ms Laura Curwood

Ext 879

[lcurwood@lbc.school.nz](mailto:lcurwood@lbc.school.nz)

## GLOBAL STUDIES - LANGUAGES

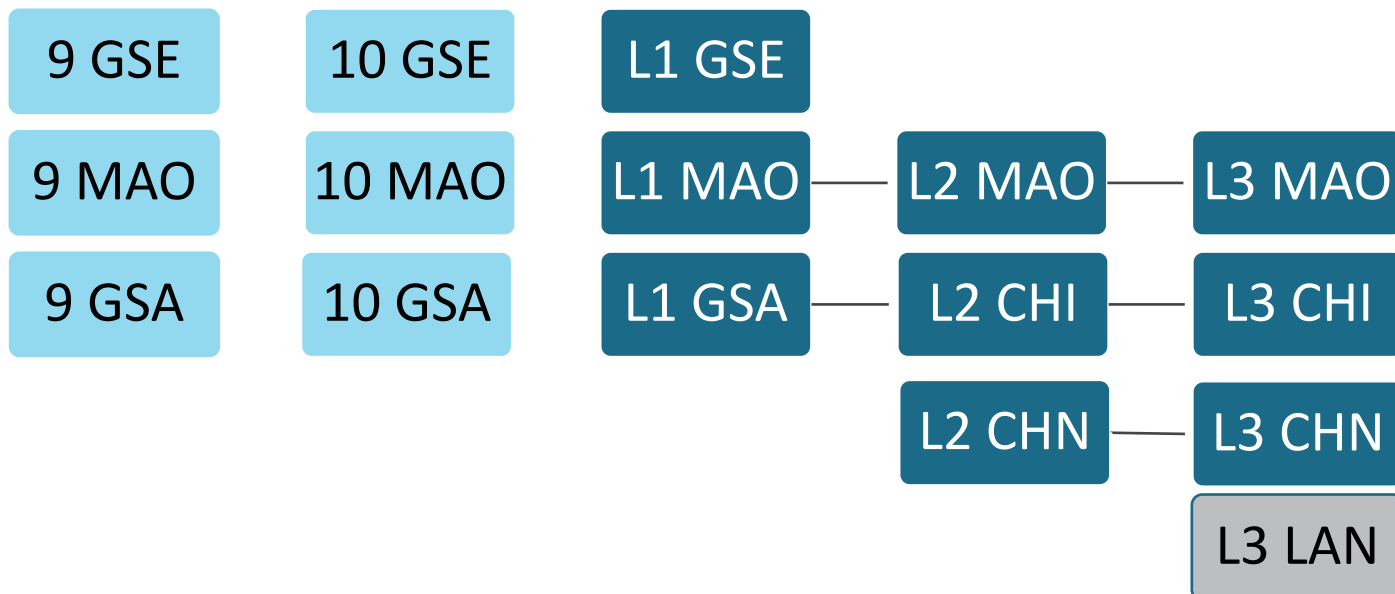

### Y9 GLOBAL STUDIES WITH EUROPEAN LANGUAGES (9GSE)

*This course leads to Global Studies at Year 10*

This is an introduction to European cultures and customs, as well as a taster of French and Spanish languages. In this course, students will learn about people and families, homes and lifestyles, festivals and food in the cultures being studied. The language component will be integrated into the course, and students will experience culture in French and Spanish speaking countries in the classroom, community and via virtual links.

Teacher in charge - Ms Laura Curwood

### Y9 TE REO MĀORI (9MAO)

*This course leads to 10MAO*

This is an introductory course in Te Reo Māori (language) and culture. Students will cover foundational cultural concepts while engaging with relevant language basics. Matariki, Hauora (Health), Pūkenga Kōrero (Conversational skills), and Toi Māori (Māori art) are some of the units covered in this course. Involvement in kapa haka is encouraged.

Teacher in charge – Ms Olivia Schertenleib

### Y9 GLOBAL STUDIES WITH ASIAN LANGUAGES (9GSA)

*This course leads to Global Studies at Year 10*

This is an introduction to Asian cultures and customs, as well as a taster of Chinese and Korean languages. In this course, students will learn about people and families, homes and lifestyles, festivals and food in the cultures being studied. The language component will be integrated into the course, and students will experience Asian culture in the classroom, community and via virtual links.

Teacher in charge - Ms Laura Curwood

## **Y10 GLOBAL STUDIES WITH EUROPEAN LANGUAGES (10GSE)**

This is an introduction to European cultures and customs, as well as a taster of French and Spanish languages. In this course, students will learn about education, leisure, tourism, and environment in the cultures being studied. The language component will be integrated into the course, and students will experience culture in French and Spanish speaking countries in the classroom, community and via virtual links. The course begins to explore social issues that these cultures are facing, as well as social actions and potential solutions.

Teacher in charge - Ms Carmen Henriquez

## **Y10 TE REO MĀORI(10MAO)**

*This course leads to L1MAO*

This course builds on the foundation culture and language aspects introduced in Year 9, with the expectation of the learning being bilingual. Broader contexts are explored and there is an expectation that students participate fully in the practical components, such as Kī o Rahi and waka ama. Units include Te Titiri o Waitangi (The Treaty), Māori occupation of Tāmaki, Toi Māori (Māori Art) and Kai Māori (Māori food).

Teacher in charge – Ms Olivia Schertenleib

## **Y10 GLOBAL STUDIES WITH ASIAN LANGUAGES (10 GSA)**

This is an introduction to Asian cultures and customs, as well as a taster of Chinese and Korean languages. In this course, students will learn about education, leisure, tourism, and environment in the cultures being studied. The language component will be integrated into the course, and students will experience Asian culture in the classroom, community and via virtual links. The course begins to explore social issues that these cultures are facing, as well as social actions and potential solutions.

Teacher in charge - Ms Victoria Yun

## L1 GLOBAL STUDIES – EUROPEAN LANGUAGE (L1 GSE)

*This course follows on from 10 GSE and leads to L2 GSE*

Year 11 Global Studies with European Languages will be following on from 10GSE and be focused on building global and cultural competencies through the learning of diverse European cultures in context. The course will focus on social issues and social actions across different European countries and cultures with emphasis on building understanding behind why different groups have different points of view and perspectives. Students will have opportunities throughout the course to investigate countries and cultures of their choice that speak different European languages.

Teacher in charge – Ms Laura Curwood

### **Students in this course will be working towards**

10 credits that are internally assessed and 5 credits that are externally assessed

Course endorsement is possible in L1 Global Studies – European language

## L1 GLOBAL STUDIES – ASIAN LANGUAGE (L1 GSA)

*This course follows on from 10 GSA and leads to L2 GSA*

Year 11 Global Studies with Asian Languages will be following on from 10GSA and be focused on building global and cultural competencies through the learning of diverse Asian cultures in context. The course will focus on social issues and social actions across different Asian countries and cultures with emphasis on building understanding behind why different groups have different points of view and perspectives. Students will have opportunities throughout the course to investigate countries and cultures with Asia of their choice. Taster language learning (which specific Asian languages offered is dependent on staffing) will continue to complement the cultural aspects and topics of this course, with other opportunities offered as co-curricular activities for those who are particularly passionate about language (for example HSK exams for Chinese).

Teacher in charge – Ms Laura Curwood

### **Students in this course will be working towards**

10 credits that are internally assessed and 5 credits that are externally assessed

Course endorsement is possible in L1 Global Studies – Asian language

## L1 TE REO MĀORI (L1 MAO)

*This course follows on from 10MAO and leads to L2 MAO*

This course extends on previous learning in the Year 10 Te Reo Māori course. Ākonga will continue the study of Tikanga Māori and will undertake internal assessments in whakarongo (listening), korero (speaking), and waihanga (creative writing), and external exams in pānui (reading) and tuhinga (writing). Research, communication-based activities and games, will be used to build competency in conversational skills, along with reading, writing, speaking and listening activities. This course leads into a Level 2 Te Reo Māori course (proposed for 2024).

Teacher in charge – Whaea Olivia Schertenleib

### **Students in this course will be working towards**

16 credits that are internally assessed and 12 credits that are externally assessed

Course endorsement is possible in L1 Te Reo Māori

This course leads to a university approved course.

## L2 TE REO MĀORI STUDIES(L2MAO)

*This course follows on from L1MAO and leads to L3MAO*

This course focuses on being able to express more in-depth ideas and opinions in Te Reo Māori. Knowledge of grammar and vocabulary is also extended. Students will be expected to use spoken Te Reo more often in the classroom. Completion of this course is essential for students wishing to study Te Reo Māori at Level 3. Involvement in Kapa Haka is expected.

Teacher in charge – Whaea Olivia Schertenleib

**Students in this course will be working towards**

16 credits that are internally assessed and 6 credits that are externally assessed

Course endorsement is possible in L2 Māori

This course leads to a university approved course.

## L3 TE REO MĀORI STUDIES (L3MAO)

*This course follows on from L2MAO*

This course covers a wide range of Māori political and social issues. At this level students should be confidently writing and speaking in Te Reo Māori. Students will be involved in leading activities both in the school and the community. Involvement in Kapa Haka is expected.

Teacher in charge – Whaea Olivia Schertenleib

**Students in this course will be working towards**

16 credits that are internally assessed and 6 credits that are externally assessed

Course endorsement is possible in L3 Māori

*This course follows on from L2MAO*

## L2 CHINESE (L2CHI)

*This course follows on from L1CHI and leads to L3CHI*

This course is aimed at non native speakers of chinese. This course further develops students' fluency in spoken Chinese whilst extending their ability to understand and express themselves at a higher level in written Chinese. Grammar and vocabulary extension will also be an integral part of the course to enable students to develop ideas at a more sophisticated level.

Teacher in charge - Ms Xiaoman Shao

**Students in this course will be working towards**

14 credits that are internally assessed and 10 credits that are externally assessed.

Course endorsement is possible in L2 Chinese

This course leads to a university approved course.

## L2 CHINESE FOR NATIVE SPEAKERS (L2CHN)

*This course leads to L3CHN*

The course is designed for Chinese native speaking students who can benefit from further development of Chinese language competency and culture. It will also focus on critical thinking and question-answering strategies aimed at high achievement in NCEA. Classes will be taught twice a week after school.

Teacher in charge - Ms Xiaoman Shao

**Students in this course will be working towards**

14 credits that are internally assessed and 10 credits that are externally assessed.

Course endorsement is possible in L2 Chinese for Native Speakers

This course leads to a university approved course.

## L3 CHINESE (L3CHI)

*This course follows on from L2CHI*

This course aims to increase fluency, comprehension and confidence in authentic language situations, as well as understanding of the culture differences. Students learn to communicate sophisticated information and opinions through more complex text types and authentic materials based on current social issues and popular topics among young people in China.

Teacher in charge - Ms Xiaoman Shao

**Students in this course will be working towards**

14 credits that are internally assessed and 10 credits that are externally assessed

Course endorsement is possible in L3 Chinese

This course is university approved.

## L3 CHINESE FOR NATIVE SPEAKERS (L3CHN)

*This course follows on from L2CHN*

This course is designed for Chinese native speaking students who can benefit from further development of Chinese language competency and culture. It will also focus on higher level critical thinking and question-answering strategies aimed at high achievement in NCEA. Classes will be taught twice a week after school.

Teacher in charge - Ms Xiaoman Shao

**Students in this course will be working towards**

14 credits that are internally assessed and 10 credits that are externally assessed

Course endorsement is possible in L3 Chinese Native for Native Speakers

This course is university approved.

## L3 LANGUAGES FOR NATIVE SPEAKERS (L3LAN)

This course is intended for native speakers of languages that are assessed as part of L3 NCEA (German, Japanese, Korean, Samoan, Spanish). It will prepare students with the necessary skills to succeed in the external exam. This course is once per week after school and is taken as a co-curricular opportunity.

Teacher in charge – Mrs Jayne Jones

**Students in this course will be working towards**

10 credits that are externally assessed (internal assessments may be offered at the discretion of the teacher)

Course endorsement is only possible in L3 Languages for Native Speakers if additional discretionary credits are gained.

This course is university approved.

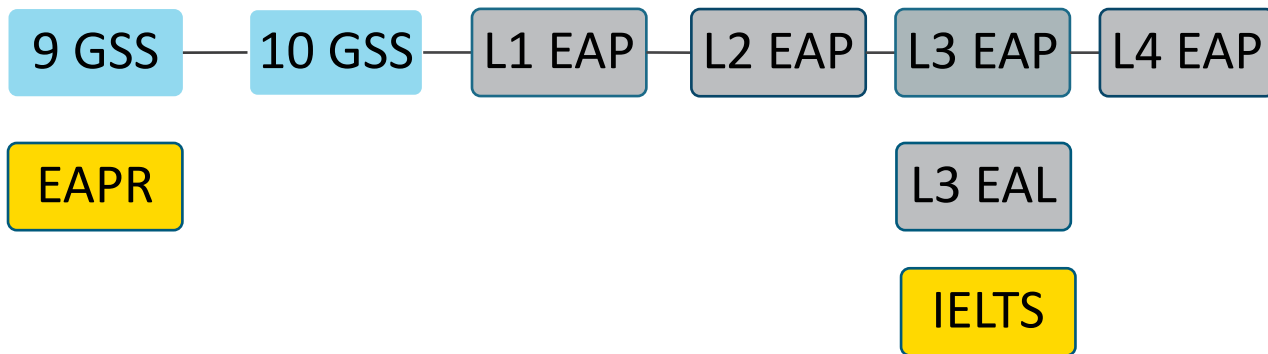

NOTE: The EAP courses are designed for English language learners, to develop their general language skills and prepare students for the increased demands of academic English. Courses will be tailored to suit individuals' needs to maximise students' progress. All students will be assessed internally throughout the year. Pathway through the senior EAP courses will depend on English level of individual student.

### RECEPTION ENGLISH FOR ACADEMIC PURPOSES (EAPR)

*This course leads to higher levels of EAP and access to mainstream subjects*

This course is a transition course designed for English language learners who have Beginners' / post-Beginners' English skills on arrival to LBC. The focus is on developing students' English language skills, as well as their confidence in language use, so that they can go on to access what is taught in mainstream subjects. The course has a strong focus on building general vocabulary and simple grammatical structures required for further studies at LBC.

Teacher in charge - Ms Laura Curwood

### YEAR 9 GLOBAL STUDIES WITH ENGLISH FOR ACADEMIC PURPOSES (9 GSS)

*This course leads to 10 Global Studies with English for Academic Purposes*

This course is a multi-level course designed for year 9 English language learners. The focus is on developing students' English language skills for general and academic purposes through developing a greater awareness and understanding of New Zealand culture and customs. The course is topic-based with an emphasis on learning about a range of global issues and their effects on New Zealand and the students' home countries. Students placed in this course will also participate in a modified social studies course created specifically for English language learners.

Teacher in charge - Ms Victoria Yun

### YEAR 10 GLOBAL STUDIES WITH ENGLISH FOR ACADEMIC PURPOSES (10 GSS)

*This course leads to senior EAP courses*

This course is a multi-level course designed for year 10 English language learners. The focus is on developing students' English language skills for general and academic purposes at a higher level through developing a greater awareness and understanding of New Zealand culture and customs. The course is topic-based with an emphasis on learning about a range of global issues and their effects on New Zealand and the students' home countries. Students placed in this course will also participate in a modified social studies course created specifically for English language learners.

Teacher in charge - Ms Victoria Yun.



## L1 ENGLISH FOR ACADEMIC PURPOSES (L1EAP)

*This course follows on from 10GSS and/or EAPR, and leads to L2EAP*

This course is designed for English language learners at Pre-Intermediate level. The focus is on developing students' reading, writing, speaking, listening and vocabulary skills for academic purposes. The course aims to support students' work in other subjects across the curriculum.

Teacher in charge - Ms Laura Curwood

**Students in this course will be working towards**

25 credits that are internally assessed and 0 credits that are externally assessed

Course endorsement is not possible in L1 English for Academic Purposes

This course does not lead to a university approved course.

## L2 ENGLISH FOR ACADEMIC PURPOSES (L2EAP)

*This course follows on from L1EAP and/or 10GSS and leads to L3EAP*

This course is designed for English language learners at intermediate level. The focus is on extending students' academic English by using topics, text and task types they will encounter in other subjects. The course will also continue to develop students' general English language skills. An additional opportunity will be offered to those at the required level to gain 3 credits towards Literacy Level 1 (NCEA).

Teacher in charge - Ms Laura Curwood

**Students in this course will be working towards**

25 credits that are internally assessed and 0 credits that are externally assessed

Course endorsement is not possible in L2 English for Academic Purposes

This course does not lead to a university approved course.

## L3 ENGLISH FOR ACADEMIC PURPOSES (L3EAP)

*This course follows on from L2EAP and leads to L4EAP*

This course aims to equip students with the English skills necessary for academic study at senior school level. The focus is on developing more advanced language skills required for academic writing, inquiry-based learning, and formal speaking. The core language skills of reading, writing, listening, speaking and vocabulary are covered through a variety of topics.

Teacher in charge - Ms Victoria Yun

**Students in this course will be working towards**

20 credits that are internally assessed and 0 credits that are externally assessed

Course endorsement is not possible in L3 English for Academic Purposes.

### L3 ENGLISH FOR ACADEMIC FOUNDATION (L3EAL)

This course can follow on from L2 or L3 EAP.

This course focuses on practical and relevant university preparation topics and skills to prepare students for the transition to a foundation course or other chosen further study. The course will allow students to strengthen their English language skills in listening, reading, writing and speaking in a range of familiar topics.

Teacher in charge - Ms Laura Curwood

#### **Students in this course will be working towards**

20 credits that are internally assessed and 0 credits that are externally assessed

Course endorsement is not possible in L3 English for Academic Foundation

This course does not lead to a university approved course.

### L4 ENGLISH FOR ACADEMIC PURPOSES (L4EAP)

Successful completion of the Advanced Reading and Writing (NCEA) components of this course will meet the literacy requirements for New Zealand University Entrance. The focus of this course is to equip students with the advanced level of academic English required by those aiming to go on to university both in New Zealand and overseas. Areas of study include formal writing and speaking, inquiry, and research projects based on Global issues.

Teacher in charge - Ms Victoria Yun

#### **Students in this course will be working towards**

22 credits that are internally assessed and 0 credits that are externally assessed. This includes 6 credits towards UE Reading and 6 credits towards UE Writing.

Course endorsement is not possible in L4 English for Academic Purposes.

### IELTS PREPARATION COURSE (IELTS)

This course is designed for English language learners who are studying short term at Long Bay College. It will prepare students for all four skills assessed in the International English Language Testing System (IELTS). Students who wish to take the exam can do so at the local IELTS centre.

Teacher in charge – Ms Laura Curwood

Course endorsement is not possible in IELTS

This course is not university approved.

# HEALTH & PHYSICAL EDUCATION

Head of Faculty –Mrs Mo Gleeson Ext 813

mgleeson@lbc.school.nz

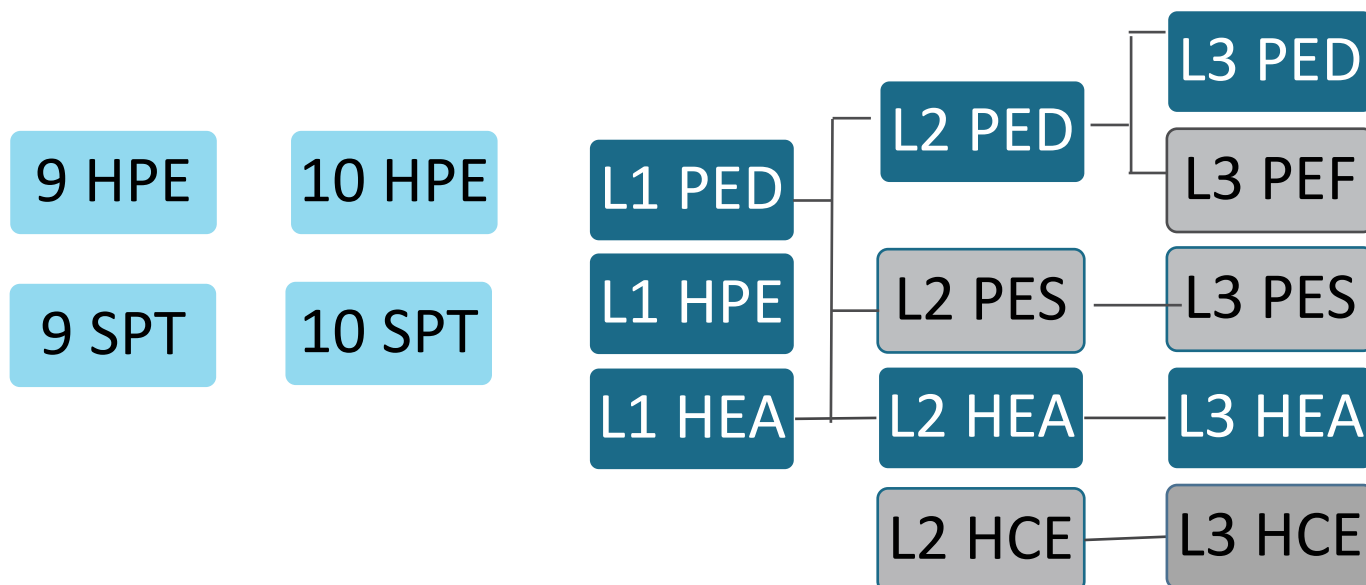

## Y9 HEALTH AND PHYSICAL EDUCATION (9HPE)

*This course leads to 10HPE*

Health and Physical Education (HPE) is a practical and theoretical based subject. In Physical Education, students gain an appreciation of participating in team and individual activities, as well as developing and mastering physical and social skills. Students will also be given the opportunity to learn the skills necessary to work safely in our Latitude 36 Fitness hub. Health Education covers: healthy lifestyles, friendships and bullying, sexuality and relationship education and alcohol education.

Teacher in charge - Mrs Mo Gleeson

## Y9 SPORTS SCIENCE AND ATHLETIC DEVELOPMENT (9SPT)

*This course leads to 10SPT*

Students will use the context of sport and physical education to develop their understanding of basic sport science and athletic development.

Students will be extended in the knowledge and understanding around anatomy, biomechanics and exercise physiology. They will learn about and experience aspects of sports psychology as well challenging socio-cultural understanding.

Students will engage in learning in both practical and theoretical contexts.

Teacher in charge - Mrs Mo Gleeson

## Y10 HEALTH AND PHYSICAL EDUCATION (10HPE)

*This course leads to L1HEA, L1PED, L1HPE*

Year 10 Health and Physical Education focuses on developing physical skills, thinking processes and aspects of Health Education. This course will have both practical and theoretical units of learning across the full year.

There will be a focus on developing students understanding of the key concepts from the Health and Physical Education curriculum as well as developing mental and physical skills from year 9.

Areas of study will include: Well-being, challenging attitudes and values, sexuality education, health promotion and mental health awareness.

Teacher in charge - Mrs Mo Gleeson

## Y10 SPORTS SCIENCE AND ATHLETIC DEVELOPMENT (10SPT)

*This course leads to L1PED, L1HPE*

Students will use the context of sport and physical education to develop their understanding of sports science and athletic development. This course aims to challenge students to apply learning around aspects of anatomy, biomechanics and exercise physiology to their own sports. Learn and apply knowledge around methods and principles of training and analyse aspects of a healthy school environment.

Students will engage in learning in both practical and theoretical contexts.

Teacher in charge - Mrs Mo Gleeson

## L1 HEALTH AND PHYSICAL EDUCATION (L1HPE)

*This course follows on from 10HPE and leads to L2HEA, L2PED, L2PES*

This course is a combined Health and Physical Education course which allows a breadth of choice at year 11. This course may also benefit students who don't consider themselves to be highly sport focused, but enjoy the practical side of physical education and the underlying concepts.

Areas of study include:

- Interpersonal skills
- Managing well being
- Self-management strategies
- Anatomy, biomechanics and exercise physiology
- Drugs and alcohol

Students will also have the opportunity to experience a range of practical activities as well as develop a deeper level of understanding of the underlying concepts of Health and Physical Education.

Teacher in charge - Mrs Mo Gleeson

**Students in this course will be working towards**

17 credits that are internally assessed and 4 credits that are externally assessed

21 credits towards Level 1 Literacy

Course endorsement is possible in L1 Health and Physical Education

This course leads to a university approved course.

## L1 HEALTH (L1HEA)

*This course follows on from 10HPE and leads to L2HEA*

Level 1 Health equips students with the foundation skills and knowledge to begin their pathway in Health Education. Health is an ever-growing industry with more opportunities opening up to students who choose this pathway. At level 1 students will learn about practical life skills and relevant Health issues.

In this course students will:

- Explore how people interact with each other through the study of interpersonal skills.
- Learn about their own personal wellbeing and look at how change can impact ones overall Health.
- Investigate issues in relation to drug and alcohol misuse.
- Gain a deeper understand around sexuality and the promotion of positive sexuality.

Teacher in charge - Miss Lucy Doran

**Students in this course will be working towards**

16 credits that are internally assessed and 4 credits that are externally assessed

20 credits towards Level 1 Literacy

Course endorsement is possible in L1 Health

This course leads to a university approved course.

## L1 PHYSICAL EDUCATION (L1PED)

*This course follows on from 10HPE and leads to L2PED, L2PES*

The course is both theoretical and practical based. Students will cover, in greater detail, anatomy, biomechanical and physiological aspects of the body, technique analysis, interpersonal skills within a team or group and participation in a range of physical activities. Students will also be given an opportunity to complete a performance improvement programme through the practical context of futsal.

Teacher in charge - Mrs Mo Gleeson

### **Students in this course will be working towards**

23 credits that are internally assessed and 0 credits that are externally assessed

7 credits towards Level 1 Literacy

Course endorsement is possible in L1 Physical Education

## L2 EARLY CHILDHOOD EDUCATION (L2HCE)

This course is designed for students who want a career pathway into the early childhood sector. Areas of study include understanding nutritional support for young children, developing aspects of well-being for children and demonstrating appropriate health and safety strategies to support young children.

The course aims to see students build useful knowledge and skills that would support entry into the work force. This is a unit standards based course and is not designed for students who are wanting to attend university.

Teacher in Charge – Miss Lucy Doran

### **Students in this course will be working towards**

21 credits that are all internally assessed.

#### **The Course leads to:**

Level 3 Early Childhood (L3HCE)

Endorsement (yes/no?) **NO**

UE approved (yes/no?) **NO**

Literacy/Numeracy credits – **N/A**

## L2 HEALTH (L2HEA)

*This course follows on from L1HEA, L1HPE and leads to L3 HEA*

This course will further develop student's knowledge and skills that will prepare them for a broad range of health-related careers. Level 2 provides students the opportunity to have a hands-on approach to Health through our unique Health promotion standard which sees students implement their own projects within the school and community. Students look at mental health and resiliency focusing on strategies to support and improve this. Students will also learn how to analyse current adolescent health issues and look at the impact on New Zealand society as well as developing strategies to address issues around sexuality gender and identity.

Teacher in charge – Miss Lucy Doran

### **Students in this course will be working towards**

15 credits that are internally assessed and 5 credits that are externally assessed

20 credits towards Level 1 Literacy

Course endorsement is possible in L2 Health

This course leads to a university approved course.

## L2 PHYSICAL EDUCATION (L2PED)

*This course follows on from L1PED, L1HPE and leads to L3 PED, L3PES, L3PEF*

This course focuses on developing the knowledge and skills related to physical activity. Students will study theoretical and practical aspects of physical education related to: personal performance, knowledge of anatomy, biomechanics and skill learning, leadership roles, safety management, the significance of participation in physical activity and principles and methods of training. A three-day outdoor education trip to Shakespear Regional Park is the highlight of the year.

Teacher in charge - Mrs Mo Gleeson

### **Students in this course will be working towards**

20 credits that are internally assessed and 0 credits that are externally assessed

16 credits towards Level 1 Literacy

Course endorsement is possible in L2 Physical Education

This course leads to a university approved course.

## L2 PRACTICAL PHYSICAL EDUCATION AND SPORTS LEADERSHIP (L2PES)

*This course follows on from L1PED, L1HPE and leads to L3 PES*

This course is both practical and theoretical. It encompasses leadership and safety (including a three-day outdoor education trip to Shakespear Regional Park), social responsibility, practical performance and demonstrating safe exercising techniques. Students will learn the traditional game of Ki-O-Rahi, as well as being given the opportunity to develop their leadership, safety and coaching skills. This course is targeted for students who are not considering future university study and cannot be taken with L2PED.

Teacher in charge - Mrs Mo Gleeson

### **Students in this course will be working towards**

19 credits that are internally assessed and 0 credits that are externally assessed

7 credits towards Level 1 Literacy

Course endorsement is possible in L2 Practical Physical Education and Leadership

This course does not lead to a university approved course.



### L3 EARLY CHILDHOOD EDUCATION (L3HCE)

*This course follows on from L2HEA*

Level 3 early childhood follows on from the Level 2 early childhood development course and continue to build students' knowledge and skills in the education and care of children in an early childhood education setting.

This course aims to prepare students to advance into higher-level early childhood education and/or care. The course gives students real industry experience (with links to the gateway programme) as well as a chance to develop their understanding of child development.

This course could be of interest to students who are thinking of further study in any areas of health science, medicine, law, psychology or social work.

Teacher in charge - Miss Lucy Doran

**Students in this course will be working towards**

30 credits that are internally assessed

This course does not lead to a university approved course.

### L3 HEALTH (L3HEA)

*This course follows on from L2HEA*

Level 3 Health is designed to look at current issues relevant to NZ and other countries. It covers current New Zealand health issues such as family violence, evaluating New Zealand health practices in relation to treating a current illness such as cancer or depression, international health issues; focusing on global poverty, current ethical issues relating to well-being looking at topics such as euthanasia or abortion.

This course could be of interest to students who are thinking of further study in any areas of health science, medicine, law, psychology or social work.

Teacher in charge - Miss Lucy Doran

**Students in this course will be working towards**

14 credits that are internally assessed and 5 credits that are externally assessed

Course endorsement is possible in L3 Health

This course is university approved.

19 credits towards Level 1 Literacy

14R, 5B credits to UE literacy (R/W/B)

### L3 PHYSICAL EDUCATION (L3PED)

*This course follows on from L2PED*

The course aims to develop and apply the knowledge base developed in Level 1 and 2 Physical Education. This includes strategies to improve performance, biomechanics, anatomy and physiology. This course also covers applying safety management strategies, which takes students on a 1-day outdoor education trip. A research assignment on current issues in NZ Sport and physical education is also offered. Students can choose to participate in the 'Tough Guy' challenge as part of their practical assessment.

Teacher in charge - Mrs Mo Gleeson

**Students in this course will be working towards**

18 credits that are internally assessed and 0 credits that are externally assessed

10 credits towards Level 1 Literacy

4 credits towards Numeracy

Course endorsement is possible in L3 Physical Education

4R credits to UE literacy (R/W/B)

This course is university approved.

### L3 PRACTICAL PHYSICAL EDUCATION AND SPORTS LEADERSHIP (L3PES)

*This course follows on from L2PES, L2PED*

This course aims to develop the leaderships skills learnt in both Level 2 Physical Education courses. Students will be given the opportunity to develop their coaching skills through the completion of the Growing Coaches PLUS Award. Students will also look at how to identify and manage risks and injuries in sporting situations as well as complete their own practical performance assessment. This course is targeted for students who are not considering further study at University.

Teacher in charge - Mrs Mo Gleeson

**Students in this course will be working towards**

27 credits that are internally assessed and 0 credits that are externally assessed

4 credits towards Numeracy

Course endorsement is not possible in L3 Practical Physical Education and Sports Leadership

This course is not university approved.

### L3 FITNESS STUDIES (L3PEF)

*This course follows on from L2PED, L2PES*

The course will have a mixture of theoretical and practical components, as well as some work placement in the schools Latitude 36 fitness hub to support usage with the junior students. The course and standards can be designed/modified to suit needs of the students, especially if some students have an interest in furthering their ambitions for the fitness industry as a career.

This course will support students who wish to consider careers in sport and recreation, coaching, and personal training.

**Students in this course will be working towards**

18 credits that are internally assessed and 0 credits that are externally assessed

Course endorsement is not possible in L3 Fitness Studies

This course is not university approved.

# MATHEMATICS

Head of Faculty –Mr Matthew Gleeson

Ext 873

[mcgleeson@lbc.school.nz](mailto:mcgleeson@lbc.school.nz)

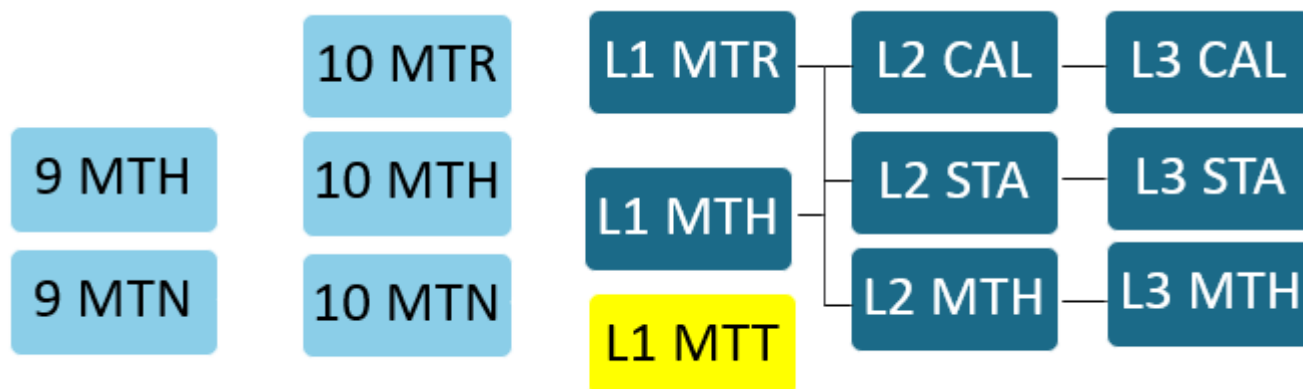

## Y9 MATHEMATICS (9MTH)

*This course leads to 10MTH*

Using entrance data as a baseline, students will progress through subsequent national curriculum levels.

Teacher in charge - Mr Matthew Gleeson

## Y9 MATHEMATICS TARGETED (9MTN)

*This course leads to 10MTH*

This course is in response to students' needs and teacher recommendations. This course offers additional numeracy support to students who are struggling to achieve in mainstream classes.

Teacher in charge - Mr Matthew Gleeson

## Y10 MATHEMATICS (10MTH)

*This course leads to L1MTH*

Students will engage in thinking mathematically and statistically in a range of meaningful contexts, across all strands of the New Zealand Curriculum, at an appropriate level.

Teacher in charge - Mr Matthew Gleeson

## Y10 MATHEMATICS ENRICHMENT (10MTR)

*This course leads to 1MTR*

Our most able Year 10 students will complete this 1-year Level 1 course, sitting a combination of internal and external assessments. A scientific calculator and electronic device (laptop or tablet) are required for this course. Students in 10MTR will be working towards 22 credits, 14 credits will be internally assessed and 8 credits will be externally assessed. This course leads to a university approved course.

Teacher in charge - Mr Matthew Gleeson

**Students in this course will be working towards**

7 credits towards Literacy

22 credits towards Numeracy

## Y10 MATHEMATICS TARGETED (10MTN)

*This course leads to 10MTH*

This course is in response to students' needs and teacher recommendations. This course offers 4 periods of additional numeracy support per week during either semester 1 or semester 2 to students who are struggling to achieve in mainstream classes.

Teacher in charge - Mr Matthew Gleeson

## L1 MATHEMATICS (L1MTH)

*This course follows on from 10MTH and leads to L2MTH, L2STA, L2CAL*

All students will complete four compulsory internal assessments and then go on to choose external standards.

Teacher in charge - Mr Matthew Gleeson

### Students in this course will be working towards

17 credits that are internally assessed and 4 credits that are externally assessed OR 14 credits that are internally assessed and 8 credits that are externally assessed depending on student choice

7 credits towards Level 1 Literacy  
21 or 22 credits towards Numeracy

Course endorsement is possible in L1 Mathematics

This course leads to a university approved course.

## L1 MATHEMATICS TRANSITION (L1MTT)

This course is designed for English language learners. They will attempt various achievement standards from NCEA level 1 and 2 according to their mathematical and literary abilities.

Teacher in charge - Mr Matthew Gleeson

This course does not lead to a university approved course.

## L1 MATHEMATICS ENRICHMENT (L1MTR)

*This course follows on from 10MTR and leads to L2, STA, CAL*

This course is designed to enrich and widen the knowledge base of our most able Year 11 students and support them towards Scholarship in Year 12 and Year 13.

Teacher in charge - Mr Matthew Gleeson

### Students in this course will be working towards

13 credits that are internally assessed and 4 credits that are externally assessed

4 credits towards Level 1 Literacy  
17 credits towards Numeracy

Course endorsement is possible in L1 Mathematics Enrichment

This course leads to a university approved course.

## L2 CALCULUS (L2CAL)

*This course follows on from L1MTH, L1MTR and leads to L3CAL, L3MTH*

This course will provide students with the necessary skills to progress to the Level 3 calculus course. An appropriate selection of internal and external Level 2 standards will be offered.

Teacher in charge - Mr Matthew Gleeson

### Students in this course will be working towards

11 credits that are internally assessed and 9 credits that are externally assessed. Course endorsement is possible in L2 Calculus.

18 credits towards Numeracy.  
This course leads to a university approved course.

## L2 MATHEMATICS (L2MTH)

*This course follows on from L1 MTH and leads to L3MTH, L3STA*

This course builds on the knowledge and skills gained in Year 11. An appropriate selection of Level 2 standards will be offered. This course will provide students with the necessary skills to progress to the L3 Mathematics course.

Teacher in charge - Mr Matthew Gleeson

### **Students in this course will be working towards**

14 credits that are internally assessed and 4 credits that are externally assessed

4 credits towards Level 1 Literacy

18 credits towards Numeracy

Course endorsement is possible in L2 Mathematics

This course leads to a university approved course.

## L2 STATISTICS (L2STA)

*This course follows on from L1MTH, L1MTR and leads to L3STA*

This course builds on the knowledge and skills gained in Year 11. This course will provide students with the necessary skills to progress to the Level 3 Statistics course.

Teacher in charge – Mr Matthew Gleeson

### **Students in this course will be working towards**

12 credits that are internally assessed and 9 credits that are externally assessed

16 credits towards Level 1 Literacy

21 credits towards Numeracy

2R credits to UE literacy (R/W/B)

Course endorsement is possible in L2 Statistics

This course leads to a university approved course.

## L3 CALCULUS (L3CAL)

*This course follows on from L2CAL*

This course is appropriate for students wishing to continue in mathematics, physical sciences, engineering or any field in which the analysis of mathematical relationships is an important tool. Topics including algebra, trigonometry and calculus are extended from Level 2 Mathematics and new ones such as complex numbers and differential equations are introduced.

Teacher in charge - Mr Matthew Gleeson

### **Students in this course will be working towards**

7 credits that are internally assessed and 17 credits that are externally assessed

24 credits towards Numeracy

Course endorsement is possible in L3 Calculus

This course is university approved.

## L3 MATHEMATICS (L3MTH)

*This course follows on from L2MTH, L2STA, L2CAL*

The topics covered by this course are based on aspects of both statistics and algebra. This course gives students the opportunity to gain 20 credits at Level 3 from the approved university entry list.

Teacher in charge - Mr Matthew Gleeson

### **Students in this course will be working towards**

16 credits that are internally assessed and 4 credits that are externally assessed

8 credits towards Level 1 Literacy

20 credits towards Numeracy

Course endorsement is possible in L3 Mathematics

This course is university approved.

## L3 STATISTICS (L3STA)

*This course follows on from L2STA*

This course is appropriate for students wishing to continue in biological and social sciences, medicine, commerce and management or any field in which the collection, analysis and interpretation of quantitative data is important.

Teacher in charge – Mr Matthew Gleeson

**Students in this course will be working towards**

12 credits that are internally assessed and 8 credits that are externally assessed

Course endorsement is possible in L3 Statistics

12 credits towards Level 1 Literacy

20 credits towards Numeracy

This course is university approved.

# PERFORMING ARTS

Head of Faculty –Ms Dannielle Savage

Ext 894

[dsavage@lbc.school.nz](mailto:dsavage@lbc.school.nz)

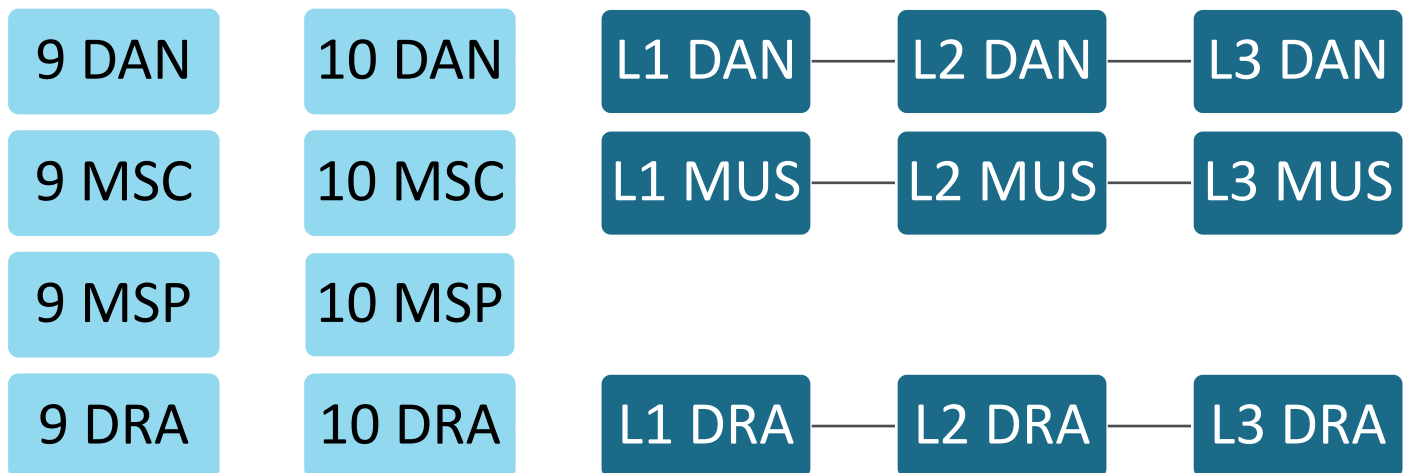

## Y9 DANCE (9DAN)

*This course leads to 10DAN*

Year 9 Dance aims to introduce basic skills that students need to perform and choreograph dance. Reflective discussions will be incorporated into each topic and support each new skill as it is learned. Appropriate dance clothing is compulsory. Dance students will develop self-management and interpersonal skills, while building self-confidence and exploring their creative self. This course is suitable for all students, beginners to experienced. Teacher in charge - Ms Kiaya Lupi

## Y9 DRAMA (9DRA)

*This course leads to 10DRA*

This half year course is designed to expand students' abilities to communicate with, understand and to work well with others and collaborate. Basic acting, movement, voice and character techniques are used to teach skills useful in classroom and extracurricular areas. This course includes dancing, acting roles, movement, character work and performance to other year levels in the Auditorium. The appropriate Drama black clothing is required. Teacher in charge – Ms Dannielle Savage

## Y9 CONTEMPORARY MUSIC (9MSC)

*This course leads to 10MSC*

This course is an introductory exploration of Music consisting of the following components:

Rise of Rock with Guitar/Ukulele, Digital Music, Group Performance, Introduction to Music Theory, Song writing/Composition, Instrumental knowledge.

Students will have the opportunity to play guitar, ukulele and a variety of percussion instruments.

Teacher in charge – Mrs Rhianna Maker

## Y9 PERFORMANCE MUSIC (9MSP)

*This course leads to 10MSP*

This course is supportive of students who have some musical experience on a performance instrument i.e. guitar, piano, trumpet, bass, violin etc and those who have not. Students will have the opportunity for solo and group performance experiences in a range of music styles and genres from small band performances to full class performances. This is excellent preparation for the performance requirements at senior levels of the Music course. Within the performance aspects, students will also have the opportunity to explore digital music, composition, music theory and the basics of an unfamiliar classroom instrument such as the guitar/ukulele or piano/keyboard.



## **Y10 DANCE (10DAN)**

*This course leads to L1 DAN*

Year 10 Dance builds and supports learning of basic techniques and skills to perform, choreograph and understand dance. During the semester students will view, discuss and experiment with different genres and styles. Thematic creations and performance of their own dances are important aspects of this course along with a research project to demonstrate understanding of styles. Appropriate dance clothing is required.

Teacher in charge - Ms Kiaya Lupi

## **Y10 DRAMA (10DRA)**

*This course leads to L1DRA*

This course stresses creativity, communication, group work and technical areas such as movement, voice, improvisation and working from scripts. The course includes elements of: Improvisation, Devised Theatre, an introduction to Greek Theatre, Melodrama and Physical Theatre. The appropriate Drama black clothing is required.

Teacher in charge – Ms Dannielle Savage

## **Y10 CONTEMPORARY MUSIC (10MSC)**

*This course leads to L1MUS*

This course builds on the 9 MSC course and a further is exploration of Music consisting of the following components:

Rise of Rock with Guitar/Ukulele, Digital Music, Group Performance, Introduction to Music Theory, Song writing/Composition, Instrumental knowledge.

Students will have the opportunity to play guitar, ukulele and a variety of percussion instruments.

Teacher in charge – Mrs Rhianna Maker

## **Y10 PERFORMANCE MUSIC (10 MSD)**

*This course leads to L1 MUS*

This course builds on the skills learnt in the Year 9 MSP course. This includes the more advanced creation, production and performance of Music. Within the performance aspects, students will also have the opportunity to explore digital music, composition, music theory and the basics of an unfamiliar classroom instrument such as the guitar/ukulele or piano/keyboard.

Teacher in charge – Mrs Rhianna Maker

## L1 DANCE (L1DAN)

*This course follows on from 10DAN and leads to L2DAN*

This course builds on the skills and techniques learnt in the previous year. Students will further develop their ability to perform, choreograph and demonstrate knowledge of dance genres effectively. Students will learn a range of dance styles and will be given the opportunity to work individually and as part of a group. Knowledge and understanding is tested in written external exams for students. Appropriate dance clothing is required. Students will perform in the dance showcase evening.

Teacher in charge - Ms Kiaya Lupi

### **Students in this course will be working towards**

16 credits that are internally assessed and 4 credits that are externally assessed

4 credits towards Level 1 Literacy

Course endorsement is possible in L1 Dance

This course leads to a university approved course.

## L1 DRAMA (L1DRA)

*This course follows on from 10DRA and leads to L2DRA*

Students build on the techniques learned in the previous year, including elements and conventions of theatre and use these in class work and performance. They study a theatre style and undertake an acting role in the class production. Knowledge and understanding of their work is tested in written feedback and in external Achievement Standards. Trips to live theatre performances are a requirement of one external exam. The appropriate Drama black clothing is required.

Teacher in charge - Ms Dannielle Savage

### **Students in this course will be working towards**

18 credits that are internally assessed and 4 credits that are externally assessed

22 credits towards Level 1 Literacy

Course endorsement is possible in L1 Drama

This course leads to a university approved course.

## L1 MUSIC (L1MUS)

*This course follows on from 10 MUS and leads to L2MUS*

This course is divided into the following areas: Performance – Students are required to perform pieces of music on their chosen performance instrument/voice, as a soloist. They also have the option to perform as a member of a group. Composition – Students learn composing skills and compose two original pieces of music. Score Reading: Students identify, describe and demonstrate understanding and application of theory and musical elements used in music scores and students will develop listening skills through melodic and rhythmic transcription.

All students must be learning a musical instrument through formal tuition either privately or through the school itinerant programme.

Teacher in charge - Mrs Rhianna Maker

### **Students in this course will be working towards**

16 credits that are internally assessed and 8 credits that are externally assessed.

10 credits towards Level 1 Literacy

Course endorsement is possible in L1 Music

This course leads to a university approved course.

## L2 DANCE (L2DAN)

*This course follows on from L1DAN and leads to L3DAN*

This course builds on the skills learnt in Level 1. Students must rely on their own skills to choreograph a dance for a group of dancers communicating and understanding specific intentions. They will continue to develop their skills of performing in a group, in pairs and as a soloist. Analysing their own work and the work of others becomes increasingly important this year. Knowledge, understanding and contexts is tested in Students written external exams. Appropriate dance clothing is required. Students will perform in the dance showcase evening.

Teacher in charge - Ms Kiaya Lupi

### **Students in this course will be working towards**

16 credits that are internally assessed and 4 credits that are externally assessed

4 credits towards Level 1 Literacy

Course endorsement is possible in L2 Dance

This course leads to a university approved course.

## L2 DRAMA (L2DRA)

*This course follows on from L1DRA and leads to L3DRA*

This subject is offered to students who have a strong interest in the Performing Arts. The course includes taking part in the class production, the study of a theatre form, and the study of acting techniques. Emphasis will be placed on the practical and performance aspects of Drama. Students will be expected to take part in class workshop situations. Written reflection and analysis are important parts of the course. Trips to live theatre performances are a requirement for the external exam and the appropriate Drama black clothing along with a workbook.

Teacher in charge - Ms Dannielle Savage

### **Students in this course will be working towards**

14 credits that are internally assessed and 4 credits that are externally assessed

18 credits towards Level 1 Literacy

13R, 4W, 4 B credits to UE literacy (R/W/B)

Course endorsement is possible in L2 Drama

This course leads to a university approved course.

## L2 MUSIC (L2MUS)

*This course follows on from L1MUS and leads to L3MUS*

This course is divided into four sections: Section A: Students are required to perform pieces of music on their chosen performance instrument/voice, as a soloist and have the option to perform as a member of a group. Section B: Students are required to compose a selection of music pieces and create an instrumentation. Section C: Students are required to describe the theoretical basis of a variety of music scores and to demonstrate aural/listening skills. Section D: Students study music works of varying styles and eras which they describe and analyse. Students must be learning a musical instrument through formal tuition either privately or through the school itinerant programme.

Teacher in charge - Mrs Rhianna Maker

### **Students in this course will be working towards**

20 credits that are internally assessed and 8 credits that are externally assessed

8 credits towards Level 1 Literacy

Course endorsement is possible in L2 Music

This course leads to a university approved course.

### L3 DANCE (L3DAN)

*This course follows on from L2DAN*

This intensive and creative course builds on the skills learned in Level 2. Students will produce a dance in groups and learn a repertoire of contrasting dances from different genres to display the varying techniques. Students will develop their analysis skills further to analyse their own learning and performance practices as well as their own and others' choreography. This course explores knowledge and understanding of dance in Aotearoa in a written external exam. Appropriate dance clothing is required.

Students will perform in the dance showcase evening.

Teacher in charge - Ms Kiaya Lupi

**Students in this course will be working towards**

14 credits that are internally assessed and 4 credits that are externally assessed

4 credits towards Level 1 Literacy  
4B credits to UE literacy (R/W/B)

Course endorsement is possible in L3 Dance

This course is university approved.

### L3 DRAMA (L3DRA)

*This course follows on from L2DRA*

This is a course for people who love performing! It is a concentrated, fast-moving course which builds on skills developed in the Level 2 Drama course. The emphasis is placed on the students' personal growth and knowledge of themselves. Initiative and self-motivation are important requirements for this course. The course is of a very practical nature and active participation is essential. Performance (both group and solo) is an integral part. Written reflection and analysis support all tasks. Trips to live theatre performances are a requirement for the external exam along with appropriate Drama black clothing and a workbook.

Teacher in charge - Mr Brendan Perkins

**Students in this course will be working towards**

14 credits that are internally assessed and 4 credits that are externally assessed

18 credits towards Level 1 Literacy  
9R, 4W, 4B credits to UE literacy (R/W/B)

Course endorsement is possible in L3 Drama

This course is university approved.

### L3 MUSIC (L3MUS)

*This course follows on from L2MUS*

Students get to choose from a range of standards that reflect their strengths and interests. Course is divided into: PERFORMANCE: Perform 2 programmes of music as a featured soloist and/or 1 programme as a member of a group.

COMPOSE / ARRANGE: Create portfolios of music compositions including song writing AS91849) and/or arrangements of specific pieces of music. Songs will be recorded in the school's recording studio. RESEARCH: In depth research into a Music topic of student's choice. EXTERNAL STANDARDS: -Students study advanced harmonic and tonal conventions in a range of scores.

Teacher in charge - Ms Dannielle Savage

**Students in this course will be working towards**

22 credits that are internally assessed and 4 credits that are externally assessed

6 credits towards Level 1 Literacy  
6R credits to UE literacy (R/W/B)

Course endorsement is possible in L3 Music

This course is university approved.

# SCIENCE

Head of Faculty – Mrs Samantha Lewis

Ext 871

[slewis@lbc.school.nz](mailto:slewis@lbc.school.nz)

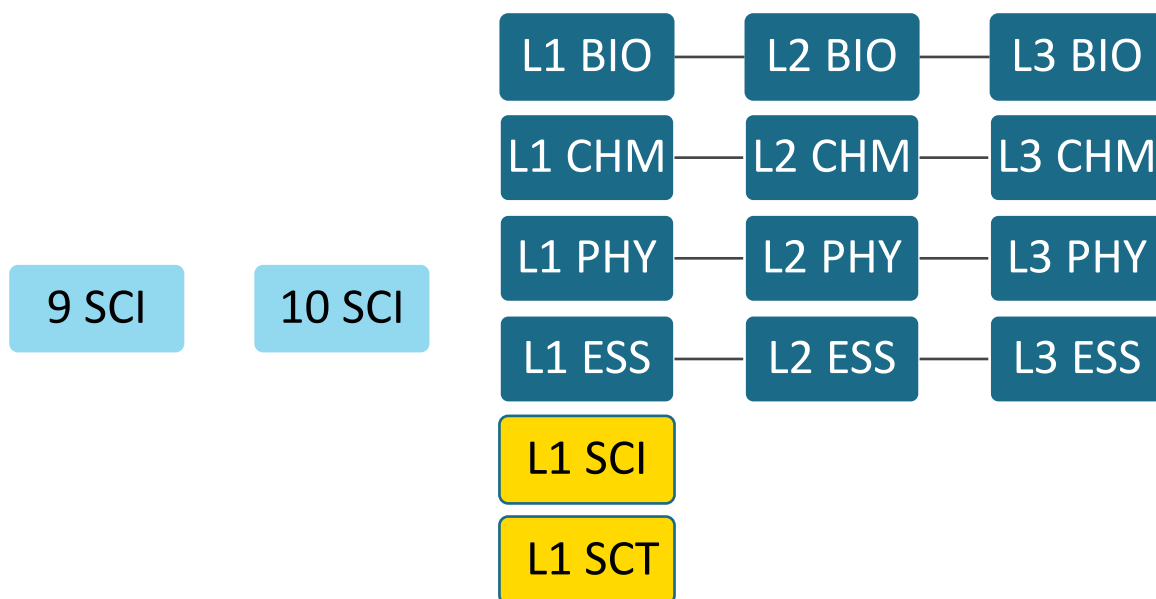

## Y9 SCIENCE (9SCI)

*This course leads to 10SCI*

This course progresses from a general introduction to Scientific processes to some very important scientific principles in Biology, Chemistry, Physics and Earth and Space.

Teacher in charge - Mrs Samantha Lewis

## Y10 SCIENCE (10SCI)

*This course leads to L1SCI, L1BIO, L1CHM, L1ESS, L1PHY*

This course continues to explore a range of important scientific concepts. This course covers all four key strands of Science including Biology, Chemistry, Physics and Earth and Space Science.

Teacher in charge - Mrs Samantha Lewis

## L1 GENERAL SCIENCE (L1SCI)

This course builds on the concepts taught at Years 9 and 10 Science. It covers ideas relating to Biology, Chemistry, Earth and Space Science and practical investigation skills. It is completely internally assessed and targeted at students who have not achieved success in 9SCI and 10SCI.

Teacher in charge - Mrs Samantha Lewis

### Students in this course will be working towards

20 credits that are internally assessed and 0 credits that are externally assessed

Course endorsement is not possible in L1 General Science

This course does not lead to a university approved course.

8 credits towards Level 1 Literacy

8 credits towards Numeracy

## L1 SCIENCE TRANSITION (L1SCT)

*This course leads to L2BIO, L2CHM, L2ESS, L2PHY*

This is a course designed for English language learners who would like to study Level 2 and 3 Science subjects in following years but do not yet have the English ability to be successful in them. It comprises of 3 external standards in Biology, Chemistry and Physics and 1 internal for science investigation skills. Students will learn science whilst developing their English ability.

Teacher in charge - Mrs Samantha Lewis

### **Students in this course will be working towards**

4 credits that are internally assessed and 12 credits that are externally assessed

4 credits towards Level 1 Literacy

4 credits towards Numeracy

Course endorsement is possible in L1 Science Transition

This course leads to a university approved course.

## L1 BIOLOGY (L1BIO)

*This course follows on from 10SCI and leads to L2BIO*

Biology is a core science subject where students will develop an understanding of fundamental biological concepts including Anatomy, microbiology, ecology, Genetics and Evolutionary Principles. Students will learn to apply knowledge of biology to explain aspects of the natural world.

Teacher in charge - Mrs Hayley Merritt

### **Students in this course will be working towards**

16 credits that are internally assessed and 4 credits that are externally assessed

4 credits towards Level 1 Literacy

Course endorsement is possible in L1 Biology

This course leads to a university approved course.

## L1 CHEMISTRY (L1CHM)

*This course follows on from 10SCI and leads to L2CHM*

Chemistry is a core science subject where students will develop an understanding of fundamental chemical concepts including organic chemistry, chemical reactivity, and the use of chemistry in technology. Students will learn to apply knowledge of chemistry to explain aspects of the material world.

Teacher in charge - Mr Brad Simons

### **Students in this course will be working towards**

11 credits that are internally assessed and 8 credits that are externally assessed

2 credits towards Level 1 Literacy

4 credits towards Numeracy

Course endorsement is possible in L1 Chemistry

This course leads to a university approved course.

## L1 EARTH AND SPACE SCIENCE (L1ESS)

*This course follows on from 10SCI and leads to L2ESS*

Earth and Space Science is a core science subject where students will develop an understanding of fundamental astronomical and geological concepts including astronomical cycles and events, investigating local geological features and formation, the carbon cycle and associated global environmental effects. Students will learn to apply knowledge of Earth and Space to explain aspects of the natural world.

Teacher in charge - Mrs Rebecca Pringle

### **Students in this course will be working towards**

20 credits that are internally assessed and 0 credits that are externally assessed

16 credits towards Level 1 Literacy

4 credits towards Numeracy

Course endorsement is not possible in L1 Earth and Space

This course leads to a university approved course.

## L1 PHYSICS (L1PHY)

*This course follows on from 10SCI and leads to L2PHY*

Physics is a core science subject where students will develop an understanding of fundamental physical concepts including mechanics, electricity and magnetism and waves. Students will learn to apply knowledge of Physics to explain aspects of the natural world.

Teacher in charge – Dr Shreyoshi Ghosh

### **Students in this course will be working towards**

10 credits that are internally assessed and 8 credits that are externally assessed

2 credits towards Level 1 Literacy

16 credits towards Numeracy

Course endorsement is possible in L1 Physics

This course leads to a university approved course.

## L2 EARTH AND SPACE SCIENCE (L2ESS)

*This course follows on from L1ESS and leads to L3ESS*

Students will develop an understanding of fundamental astronomical and geological concepts including star characteristics and life cycle, planetary and solar system formation, volcanoes, earthquakes and local surface feature formation as well as investigating a global environmental issue. Students will learn to apply knowledge of Earth and Space to explain aspects of the material world. This course is designed to prepare students for tertiary study in one of the Sciences.

Teacher in charge - Mrs Rebecca Pringle

### **Students in this course will be working towards**

12 credits that are internally assessed and 8 credits that are externally assessed

20 credits towards Level 1 Literacy

4 credits towards Numeracy

Course endorsement is possible in L2 Earth and Space

This course leads to a university approved course.

## L2 BIOLOGY (L2BIO)

*This course follows on from L1BIO and leads to L3BIO*

This course builds on Level 1 Biology knowledge. Students will develop an understanding of fundamental biological concepts including Zoology, Cytology, Ecology, Genetics and Evolutionary Principles. Students will learn to apply knowledge of biology to explain aspects of the natural world. This course is designed to prepare students for tertiary study in the Biological Sciences.

Teacher in charge - Mrs Hayley Merritt

### **Students in this course will be working towards**

11 credits that are internally assessed and 8 credits that are externally assessed

19 credits towards Level 1 Literacy

Course endorsement is possible in L2 Biology

This course leads to a university approved course.

## L2 CHEMISTRY (L2CHM)

*This course follows on from L1CHM and leads to L3CHM*

This course builds on Level 1 Chemistry knowledge. Students will develop an understanding of fundamental chemical concepts including atomic structure and bonding, organic chemistry, and chemical reactivity. Students will learn to apply knowledge of chemistry to explain aspects of the material world. This course is designed to prepare students for tertiary study in one of the Sciences.

Teacher in charge - Mr Brad Simons

### **Students in this course will be working towards**

7 credits that are internally assessed and 13 credits that are externally assessed

13 credits towards Level 1 Literacy

4 credits towards Numeracy

Course endorsement is possible in L2 Chemistry

This course leads to a university approved course.

## L2 PHYSICS (L2PHY)

*This course follows on from L1PHY and leads to L3PHY*

This course builds on Level 1 Physics knowledge. Students will develop an understanding of fundamental physical concepts including mechanics, electricity, and modern physics. Students will learn to apply knowledge of physics to explain aspects of the material world. This course is designed to prepare students for tertiary study in one of the Sciences.

Teacher in charge – Dr Shreyoshi Ghosh

### **Students in this course will be working towards**

10 credits that are internally assessed and 12 credits that are externally assessed

22 credits towards Level 1 Literacy

16 credits towards Numeracy

Course endorsement is possible in L2 Physics

This course leads to a university approved course.



### L3 BIOLOGY (L3BIO)

*This course follows on from L2BIO*

This subject builds on Level 2 Biology knowledge. Students will develop an understanding of fundamental biological concepts including Homeostasis, Socio-scientific issues, Human Evolution, Plant and Animal Behaviour and Applications of Biotechnology. This course is designed to prepare students for tertiary study in the Biological Sciences.

Teacher in charge - Mrs Hayley Merritt

**Students in this course will be working towards**

9 credits that are internally assessed and 9 credits that are externally assessed

Course endorsement is possible in L3 Biology

19 credits towards Level 1 Literacy

9R, 9B credits to UE literacy (R/W/B)

This course is university approved.

### L3 CHEMISTRY (L3CHM)

*This course follows on from L2CHM*

This course builds on Level 2 Chemistry knowledge. Students will develop an understanding of fundamental chemical concepts including thermochemistry, organic chemistry, implications of chemistry in the real world. Students will learn to apply knowledge of chemistry to explain aspects of the material world. This course is designed to prepare students for tertiary study in one of the Sciences.

Teacher in charge - Mr Brad Simons

**Students in this course will be working towards**

9 credits that are internally assessed and 10 credits that are externally assessed

Course endorsement is possible in L3 Chemistry

16 credits towards Level 1 Literacy

4W credits to UE literacy (R/W/B)

This course is university approved.

### L3 EARTH AND SPACE SCIENCE (L3ESS)

*This course follows on from L2ESS*

This course builds on L2ESS knowledge covering both practical and theoretical concepts of Earth and Space systems. It is an academic course which includes topics in ocean, atmosphere and astronomy. This is suited to students wishing to study courses such as Environmental Science, Marine Biology, Climate Science and Geography.

Teacher in charge - Mrs Rebecca Pringle

**Students in this course will be working towards**

12 credits that are internally assessed and 8 credits that are externally assessed

Course endorsement is possible in L3 Earth and Space Science

20 credits towards Level 1 Literacy

4 credits towards Numeracy

4W, 16B credits to UE literacy (R/W/B)

This course is university approved.

## L3 PHYSICS (L3PHY)

*This course follows on from L2PHY*

This course builds on Level 2 Physics knowledge. Students will develop an understanding of fundamental physical concepts including mechanics, electricity, waves and modern physics. Students will learn to apply knowledge of physics to explain aspects of the material world. This course is designed to prepare students for tertiary study in one of the Sciences.

Teacher in charge – Dr Shreyoshi Ghosh

### **Students in this course will be working towards**

10 credits that are internally assessed and 16 credits that are externally assessed

22 credits towards Level 1 Literacy

Course endorsement is possible in L3 Physics

This course is university approved.

# SOCIAL SCIENCES

Head of Faculty – Miss Lauren Wing

Ext 863

[lwing@lbc.school.nz](mailto:lwing@lbc.school.nz)

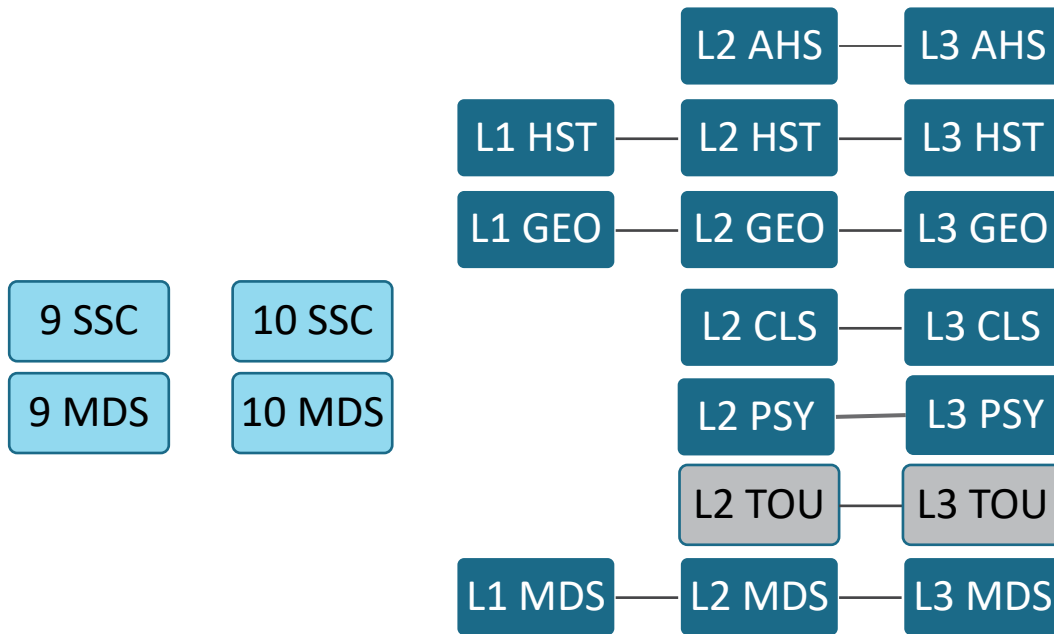

## Y9 SOCIAL SCIENCE (9SSC)

*This course leads to 10SSC*

The Year 9 Social Science course draws from the Social Sciences and the Humanities. The course is thematically based, exploring a range of contexts across time, locations and societies. Themes explored include our place in society, making choices, and protecting resources. The course is designed to stimulate curiosity and imagination, in alignment with NZC Levels 4-5 of the Social Sciences strands. The course builds student general knowledge, literacy and research skills.

Teacher in charge – Miss Lauren Wing

## Y9 MEDIA STUDIES (9MDS)

*This course leads to 10MDS*

This is an exciting introduction into the world of the creative industries. We look at film and television; social media; computer games and the influence that companies like Disney and Instagram wield. Media students are curious about how messages in various media texts are constructed, who is constructing the message and why are they deliberately manipulating their audiences. In this course students will learn how to design, write, shoot and edit a film; how to design products that targets a specific audience; and how to appreciate and analyse how different people read media texts from their unique perspectives.

Teacher in charge - Miss Adrienne Bishop

## Y10 SOCIAL SCIENCE (10SSC)

*This course leads to L1HST, L1GEO, L1MDS*

The Year 10 Social Science course draws from the Social Sciences and the Humanities. The course is thematically based, exploring a range of contexts across time, locations and societies. Themes explored include global connections, bicultural Aotearoa/New Zealand and human rights and how people have sought them. The course is designed to stimulate curiosity and imagination, in alignment with Level 5 of the Social Sciences strands. The course builds student general knowledge, literacy and research skills.

Teacher in charge – Miss Lauren Wing

## Y10 MEDIA STUDIES (10MDS)

*This course leads to L1 MDS*

This is a dynamic exploration into the world of the creative industries. Media students are challenged to look at how different societies present themselves through the media it creates. We look at film and television; social media; computer games; advertising; journalism and we look at the motivations and manipulations of the media industries biggest companies. In this course students will learn how to design, write, shoot and edit a film; how to design products that targets a specific audience; and how to appreciate and analyse how different people read media texts from their unique perspectives.

Teacher in charge - Miss Adrienne Bishop

## L1 GEOGRAPHY (L1GEO)

*This course follows on from 10SSC and leads to L2GEO*

This year focuses on the following topics: • Extreme natural events - tsunamis • Geographic skills. Global pattern of coffee production. Sustainability of the Maldives environment. Geographical skills such as mapping and important geographic concepts will be learned, and students will complete an individual research assignment. Assessment will be by an external examination and internal assessments.

Teacher in charge - Mrs Justine McIntosh

**Students in this course will be working towards**

10 credits that are internally assessed and 8 credits that are externally assessed  
Course endorsement is possible in L1 Geography

14 credits towards Level 1 Literacy  
3 credits towards Numeracy

This course leads to a university approved course.

## L1 HISTORY (L1HST)

*This course follows on from 10SSC and leads to L2HST*

Students will develop an understanding of the causes, consequences and perspectives of events of significance to New Zealanders through the study of 20th Century topics that have shaped the lives of people and society. Topics may include: • World War Two: origins, key battles, the home front and the atomic bomb • Racism and civil rights in the USA (1954-68) • Brown Power in New Zealand (1970s): Ngā Tamatoa and the Polynesian Panthers.

Teacher in charge - Mr Terry Chee

**Students in this course will be working towards**

12 credits that are internally assessed and 8 credits that are externally assessed  
Course endorsement is possible in L1 History

20 credits towards Level 1 Literacy

This course leads to a university approved course.

## L1 MEDIA STUDIES (L1MDS)

*This course follows on from 10MDS and leads to L2MDS*

This year students will continue to explore the Mass Media. They will develop key skills in close reading a scene from a film, looking at the director's use of camerawork, lighting, sound and costume to explore an idea. They will also be following how an issue or event is explored by print, television and digital media (internet/social networking sites). Students will be looking at the regulations attached to broadcasting and the impact of social media on companies revenues. A large portion of this course is dedicated to practical film making where students are challenged to plan, design and produce a short film which requires a significant time commitment in Term 2.

Teacher in charge - Miss Adrienne Bishop

### **Students in this course will be working towards**

13 credits that are internally assessed and 8 credits that are externally assessed

21 credits towards Level 1 Literacy

Course endorsement is possible in L1 Media Studies

This course leads to a university approved course.

## L2 ART HISTORY (L2AHS)

*This course follows leads to L3AHS*

Art History is a subject which allows you to understand the essence of society's ideas and priorities through unravelling how this is mirrored in the lives and artworks of artists.

The topic of study for this course is "Towards Modernism" which covers 19<sup>th</sup> Century Art in France. This was a time of dramatic social and political change in world history brought on by the Age of Enlightenment, French Revolutions and the Industrial Age. Art movements from Neo-Classicism to Post Impressionism are studied to unravel artists' ideas and Interpretation of reality in this modern and uncertain age.

Study in Art History is complementary to other subjects such as History and Classics and does not need to be taken in conjunction with Practical Art. It is however a valuable subject for Visual Art students and is especially beneficial to those students interested in studying Art, Design or Architecture at a Tertiary level.

Students choosing this course must show an ability to respond to teacher led research and written tasks in the classroom and the ability to work independently. This course requires strong analytical and literacy skills.

Teacher in charge - Mrs Liese Strong

18 credits towards Level 1 Literacy

10R, 8B credits to UE literacy (R/W/B)

24 credits towards Level 1 Literacy

12R, 12B credits to UE literacy (R/W/B)

### **Students in this course will be working towards**

12 credits that are internally assessed and 12 credits that are externally assessed

Course endorsement is possible in L2 Art History

This course leads to a university approved course.

## L2 CLASSICS (L2CLS)

*This course follows on from L1ENG, L1ENE, L1HST and leads to L3CLS*

Classics is about the great civilisations of Ancient Greece and Ancient Rome. The Level 2 course focuses on the history, society, mythology, literature, architecture, and art of Ancient Greece. Assessments cover the Battle of Thermopylae, Homer's great tale The Odyssey, as well as the sculpture and architecture of Ancient Athens.

Teacher in charge - Mr Dean Thompson

### **Students in this course will be working towards**

10 credits that are internally assessed and 8 credits that are externally assessed

18 credits towards Level 1 Literacy

10R, 8B credits to UE literacy (R/W/B)

Course endorsement is possible in L2 Classics

This course leads to a university approved course.

## L2 GEOGRAPHY (L2GEO)

*This course follows on from L1GEO and leads to L3GEO*

Geography Level 2 focuses on 2 major areas of study: • Differences in development and Geographic skills • Also studied are the development of important geographic concepts and the understanding of contemporary geographic issues and problems. The 3 day field trip to the Tongariro Volcanic Centre is an integral part of the course and students must be willing and able to go on this field trip.

Teacher in charge - Mrs Justine McIntosh

### **Students in this course will be working towards**

11 credits that are internally assessed and 8 credits that are externally assessed

19 credits towards Level 1 Literacy

5 credits towards Numeracy

Course endorsement is possible in L2 Geography

This course leads to a university approved course.

## L2 HISTORY (L2HST)

*This course follows on from L1HST and leads to L3HST*

In this course students will study 3 main topics (subject to change): • Nuclear issues in New Zealand • Conflict in Vietnam 1945-1975 • The Russian Revolution. Success in this subject requires strong literacy skills to cope with the reading, writing and research components.

Teacher in charge - Mr Terry Chee

### **Students in this course will be working towards**

15 credits that are internally assessed and 4 credits that are externally assessed

19 credits towards Level 1 Literacy

14R, 4W credits to UE literacy (R/W/B)

Course endorsement is possible in L2 History

This course leads to a university approved course.

## L2 MEDIA STUDIES (L2MDS)

*This course follows on from L1MDS and leads to L3MDS*

In this course students will develop their keen interest in the media, from films to the internet, and its use to reflect and affect the social, political, historical and economic climate of the time in which they were made. Within this course we will look at the manipulation of the press, the influence of social media, how narrative techniques drive directorial decision making in films and how our heroes and villains reflect the socio-political concerns of the time. A large portion of this course is dedicated to practical film making where students are challenged to plan, design and produce a short film which requires a significant time commitment in Term 2.

Teacher in charge - Miss Adrienne Bishop

### **Students in this course will be working towards**

14 credits that are internally assessed and 4 credits that are externally assessed

18 credits towards Level 1 Literacy

7B credits to UE literacy (R/W/B)

Course endorsement is possible in L2 Media Studies

This course leads to a university approved course.

## L2 PSYCHOLOGY (L2PSY)

*This course leads to L3 PSY*

In this course students will develop an understanding of the Science and study of Psychology. This includes methods of psychological research, how psychological theory is applied in Clinical practice to explain behaviours such as Addiction and Schizophrenia. The ethical principles underpinning psychological research with a focus on controversial studies into social Influence and obedience. Students will conduct research to investigate the purpose of sleep and dreaming.

Teacher in charge – Mr Eric Wheeler

### **Students in this course will be working towards**

All credits are internally assessed.

21 credits towards Level 1 Literacy

Course endorsement is not possible in L2 Psychology.

21 credits

This course leads to a university approved course.

## L2 TOURISM (L2TOU)

*This course follows on from L1HST, L1GEO, L1MDS and leads to L3TOU*

Tourism is a constantly growing industry in New Zealand and therefore it is useful to achieve some of the Tourism Unit Standards before going on to study the subject at a tertiary institution.

Teacher in charge - Mr Martyn Longstaff

### **Students in this course will be working towards**

20 credits that are internally assessed and 0 credits that are externally assessed

Course endorsement is not possible in L2 Tourism

This course does not lead to a university approved course.

## L3 ART HISTORY (L3AHS)

*This course follows on from L2AHS*

Art History is a subject which allows you to understand the essence of society's ideas and priorities through unravelling how this is mirrored in the lives and artworks of artists.

The Topic of study is "Early Modernism" which takes place in the first half of the 20th Century, a period which covers both world wars and ground-breaking advances in science, technology and psychology. This was also a period of accelerated social, political, and philosophical change. Art movements from Cubism to Surrealism are studied to unravel artists' reinvention and interpretation of reality in this modern and uncertain age.

Study in Art History is complementary to other subjects such as History and Classics and does not need to be taken in conjunction with Practical Art. It is however a valuable subject for Visual Art students and is especially beneficial to those students interested in studying Art, Design or Architecture at a Tertiary level.

Students choosing this course must show an ability to respond to teacher led research and written tasks in the classroom and the ability to work independently. This course requires strong analytical and literacy skills.

Teacher in charge - Mrs Liese Strong

Students in this course will be working towards

12 credits that are internally assessed and 12 credits that are externally assessed

20 credits towards Level 1 Literacy

12R, 12B credits to UE literacy (R/W/B)

Course endorsement is possible in L3 Art History

This course is university approved

## L3 CLASSICS (L3CLS)

*This course follows on from L2CLS*

Classics is about the great civilisations of Ancient Greece and Ancient Rome. The Level 3 course focuses mostly on the history, society, mythology, entertainment, literature, politics, architecture and art of Ancient Rome. Assessments cover propaganda in Roman art and architecture, the nature of heroism throughout time, and Virgil's The Aeneid.

Teacher in charge - Mr Dean Thompson

**Students in this course will be working towards**

8 credits that are internally assessed and 12 credits that are externally assessed

20 credits towards Level 1 Literacy

Course endorsement is possible in L3 Classics

This course is university approved.

## L3 GEOGRAPHY (L3GEO)

*This course follows on from L2GEO*

The course covers 2 major areas: • The study of natural coastal processes at work within Omaha. Selecting and applying skills and important geographic ideas to topics. • Sustainability of Tourism is studied with a 3 day field trip to Rotorua • Studies of contemporary geographic issues on Human Trafficking and Modern Day Piracy. Field work is an integral part of the course and assessment. Students must be able to go on these field trips.

Teacher in charge - Mrs Justine McIntosh

**Students in this course will be working towards**

11 credits that are internally assessed and 8 credits that are externally assessed

19 credits towards Level 1 Literacy

5 credits towards Numeracy

Course endorsement is possible in L3 Geography

3R, 8B credits to UE literacy (R/W/B)

This course is university approved.



### L3 HISTORY (L3HST)

*This course follows on from L2HST*

Students study two topics in depth. The first topic is The Weimar and Nazi Germany, 1918-45. In the second topic, students conduct research on a topic of their choice as part of the internal assessment. This provides the opportunity to focus on an area of history that is of particular interest to the student as well as developing their skills as Historians.

Teacher in charge - Mr Terry Chee

#### **Students in this course will be working towards**

15 credits that are internally assessed and 6 credits that are externally assessed

21 credits towards Level 1 Literacy

6B credits to UE literacy (R/W/B)

Course endorsement is possible in L3 History

This course is university approved.

### L3 MEDIA STUDIES (L3MDS)

*This course follows on from L2MDS*

In this course students will develop their keen interest in the media as an industry and its cause and effect relationship with its audience. We will focus on exploring the way a media text can be read in different ways dependent upon the audience's own experience of the world around them. Within this course we will look at how aspects of a director's style influence the reading of a text, aspects of genre and how the controls of a media industry reflect the products on the market. A large portion of this course is dedicated to practical film making where students are challenged to plan, design, and produce an 8 minute short film which requires a significant time commitment in Term 1.

Teacher in charge - Miss Adrienne Bishop

#### **Students in this course will be working towards**

13 credits that are internally assessed and 4 credits that are externally assessed

17 credits towards Level 1 Literacy

Course endorsement is possible in L3 Media Studies

This course is university approved.

### L3 TOURISM (L3TOU)

*This course follows on from L2TOU*

This course is the second half of the National Certificate in Tourism Level 2. Tourism electives can be done on their own without the full certificate being taken, as can Tourism Core Skills.

Teacher in charge – Mr Martyn Longstaff

#### **Students in this course will be working towards**

21 credits that are internally assessed and 0 credits that are externally assessed

Course endorsement is not possible in L3 Tourism

This course is not university approved.

## L3 PSYCHOLOGY (L3PSY)

*This course follows on from L2 PSY*

In this course students will develop an understanding of the Science and study of Psychology. This includes conducting student led psychological research, how psychological theory is applied in within a Field of practice (Forensic psychology). Understanding how psychology looks to explain human attraction and what is intelligence will be investigated. The Issues impacting psychological practice including Cultural and Gender Bias as well as the Ethical issues of using animals or children in psychological research.

Teacher in charge – Mr Eric Wheeler

**Students in this course will be working towards**

19 credits are internally assessed.

22 credits towards Level 1 Literacy

3 credits are externally assessed.

This course leads to a university entrance approved course.

# TECHNOLOGY

Head of Faculty – Ms Jana Durdevic

jdurdevic@lbc.school.nz

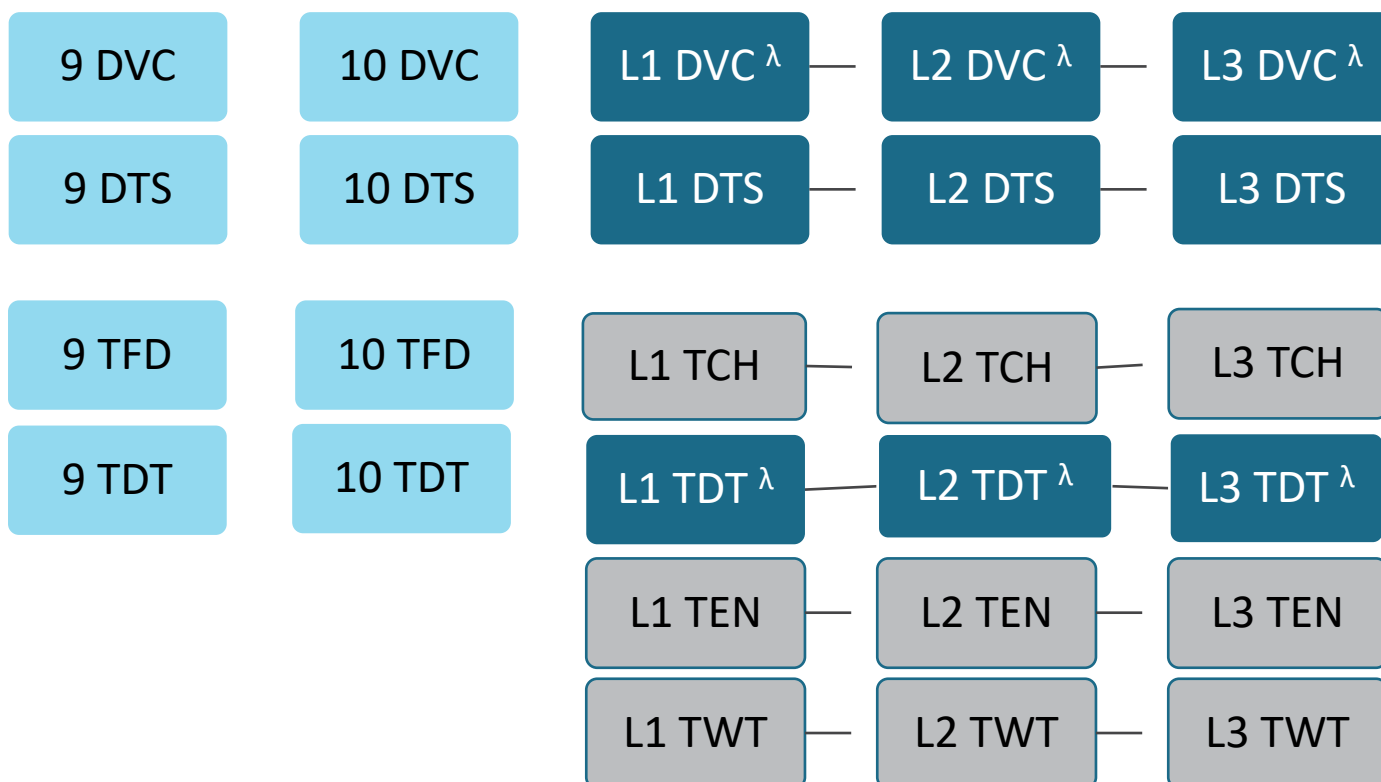

<sup>λ</sup> Portfolio subjects are indicated with this symbol <sup>λ</sup>. If choosing portfolio subjects, students are recommended to choose a maximum of two.

## Y9 DESIGN AND VISUAL COMMUNICATION (9DVC)

*This course leads to 10DVC*

A one semester course that begins with the application of basic theory and practical skills needed in both architecture and product design.

Development towards the key areas includes: • Understanding of design ideation and refinement • Understanding of design context and real-world problem solving • Design sketching, crating, rendering • Architecture case studies • Engineering and technical drawing content • Communication design

High end Technology skills: • Adobe Software • Autodesk Software • 3D Printer • Laser cutter • Model making/prototyping

Teacher in charge - Ms Chloe Mclsaac

## Y9 DIGITAL TECHNOLOGY STUDIES (9DTS)

*This course leads to 10DTS*

This one semester course focuses on Web Development. It also covers computer science theory and provides an introduction to Python programming.

Web and App development includes: • Human Computer Interaction (HCI) using Nielsen's Usability Heuristics • Design Principles and Elements • File Management Procedures • Web design using HTML and CSS (Replitt) • Wireframing and Mockups (Prototyping) Computer Science and an introduction to Python Programming • Data Representation (Understanding Binary) • Error Control Encoding (Check Digits and Parity) • Algorithms (Search and Sort) • Python Programming (sequence, selection and iteration.)

Teacher in charge - Mrs Michelle Gallagher

## Y9 FOOD TECHNOLOGY (9TFD)

*This course leads to 10TFD*

With a strong focus on health and safety, this course consists of theory driven practical tasks designed to develop students foundation level skills when executing a range of recipes. These recipes draw from and add to the cultural diversity within the Long Bay College context. There is a high level of importance placed on time management, independence in the kitchen and on being a professional and valuable member of a team.

Teacher in charge - Mrs Robyn Hunn & Mrs Debra Scragg

## Y9 DESIGN & TECHNOLOGY (9TDT)

*This course leads to 10TDT*

This course provides a practical introduction into Hard Materials and Electronics through specifically designed 'design and make' project tasks. Skills taught include the design process, the use of Adobe design, Software and Laser etching and Cutting.

Teacher in charge – Mr Matt Overington

## Y10 DESIGN AND VISUAL COMMUNICATION (10DVC)

*This course leads to L1DVC*

A one semester course that extends both practical and theory skills in Architecture and product design. Those students not involved in year 9 DVC gain knowledge, whilst acting as a developmental refresher for those who did Yr 9 DVC.

Further development towards the key areas includes:

- Understanding of design ideation and refinement
- Understanding of design context and real-world problem solving
- Design sketching, crating, rendering
- Architecture case studies
- Engineering and technical drawing content
- Communication design. High end Technology skills;
- Adobe Software
- Autodesk Software
- 3D Printer
- Laser cutter
- Model making/prototyping

Teacher in charge – Ms Choe Mclsaac

## Y10 DIGITAL TECHNOLOGY STUDIES (10DTS)

*This course leads to L1DTS, L1TDT*

This one semester course focuses on 3D Modelling, Game Animation, Web design (html +CSS) and Advanced Python programming.

3D Modelling, Web design, Game Animation. and Advanced Python programming will include:

- Planning (Pseudocode)
- Python Programming (inputs, outputs, sequence iteration to design, develop, create and test (Debug) a computer program
- 3D Modelling using Blender
- Project Management (Gantt Charts) to plan and design a website.
- Students will create their own game (includes creating their own sprites, backgrounds etc)

Teachers in charge - Mrs Michelle Gallagher & Mr Tony Bailey

## Y10 FOOD TECHNOLOGY (10TFD)

*This course leads to L1TCH*

A semester course that consists of project based outcomes which build on and challenge student practical ability. Beyond practical product development students are introduced to vocational pathway standards that are outsourced via Service HQ. With learning scaffolded to develop critical thinking and problem solving in relation to operational processes; students will be introduced to flavour profiles, plating deconstruction and “High Tea” presentation and tradition.

Teacher in charge - Mrs Robyn Hunn & Mrs Debra Scragg

## Y10 DESIGN & TECHNOLOGY (10TDT)

*This course leads to L1TDT, L1TWT, L1TEN*

This course consists of a combination of Hard Materials and Electronic based projects. Students will learn about the theory of materials and basic electronics along with designing and making products that incorporate all of these areas.

Skills taught in year 9 (Adobe Design Software Design Process, laser Cutting) will be reinforce in this course.

Teacher in charge – Mr Matt Overington

## L1 DESIGN AND VISUAL COMMUNICATION (L1DVC) λ

*This course follows on from 10DVC and leads to L2DVC*

There are two areas of study: • Spatial Design - architecture, landscape graphics, perspective drawing • Product Design - engineered products, consumer products, media products and associated drawing systems. A selected body of work will be promoted to an audience.

Teacher in charge - Ms Jana Durdevic

### **Students in this course will be working towards**

10 credits that are internally assessed and 9 credits that are externally assessed

6 credits towards Numeracy

4 credits towards Literacy

Course endorsement is possible in L1 Design and Visual Communication

This course leads to a university approved course.

## L1 DIGITAL TECHNOLOGY STUDIES (L1DTS)

*This course follows on from 10DTS and leads to L2DTS*

Students will learn how to: • Develop a website using HTML + CSS • Take end users into account and use the process of iteration throughout the design, development and testing phase • Effectively use design elements • Address relevant implications in their outcomes, e.g. understanding the correct ethical procedures when producing, using and storing data • Create a flexible and robust program using the Python programming language whilst following python conventions • Test and debug in an organised way with expected, boundary and unexpected data • Demonstrate understanding of Human Computer Interaction using Neilsens Heuristics (3 hour external paper). Students also have the opportunity to complete an industry certification in either Microsoft Office or Adobe products.

Teacher in charge - Mrs Michelle Gallagher

### **Students in this course will be working towards**

12 credits that are internally assessed and 3 credits that are externally assessed

11 credits towards Level 1 Literacy

Course endorsement is possible in L1 Digital Technology

This course leads to a university approved course.

## L1 DESIGN AND TECHNOLOGY (L1TDT) λ

*This course follows on from 10TDT, 10DTS and leads to L2TDT, L2 TWT & L2 TEN*

This course is a University approved, Achievement Standard course in which students design and build two projects, one that is furniture based and the other a blue tooth speaker. Students will design and make these projects using wood, metals, plastics, soft materials and electronics. They will also engage in the use of Adobe software laser cutting and CAD software.

Teacher in charge - Mr Allen French

### **Students in this course will be working towards**

20 credits that are internally assessed

This course leads to a university approved course.

## L1 ENGINEERING (L1TEN)

*This course follows on from 10TDT and leads to L2TEN*

The course consists of a combination of written and practical work. Students will be assessed on their competence in using tools and machinery in the Engineering workshop. Understanding of materials and safe working practices will also be assessed. This course is designed for students interested in taking up an apprenticeship in any of the related fields

Teacher in charge - Mr Matt Overington

### **Students in this course will be working towards**

21 credits that are internally assessed and 0 credits that are externally assessed

Course endorsement is not possible in L1 Engineering

This course does not lead to a university approved course.

## L1 WOOD TECHNOLOGY (L1TWT)

*This course follows on from 10TDT and leads to L2TWT*

This is a NCEA Unit Standard Technology course using wood-based products as a materials medium. Students will gain credits for success with design, brief development, individual production of a prototype, and documentation of processes. This course is designed as a skills and knowledge prerequisite for Level 2 Wood Technology. An article of furniture will be made to take home.

Teacher in charge - Mr Jeff Evans

### **Students in this course will be working towards**

18 credits that are internally assessed and 0 credits that are externally assessed

Course endorsement is not possible in L1 Wood Technology

This course does not lead to a university approved course.

## L1 CUISINE AND HOSPITALITY STUDIES (L1 TCH)

*This course follows on from 10TFD and leads to L2TCH*

This is a practical based course which includes units of learning recognised and linked with Polytechnics and Cuisine Institute Standards. Students will also be expected to complete university approved standards. This course is ideal for those seeking employment in this field or going on to advanced studies in Chef work, Hotel Management, Tourism or starting their own catering business. Students will be expected to cater for functions.

Teacher in charge - Mrs Robyn Hunn

### **Students in this course will be working towards**

22 credits that are internally assessed and 0 credits that are externally assessed

Course endorsement is not possible in L1 Hospitality.

This course does not lead to a university approved course

## L2 DESIGN AND VISUAL COMMUNICATION (L2DVC) λ

*This course follows on from L1DVC and leads to L3DVC*

Two, half year projects from a student driven perspective. Brief, context and specifications are researched extensively by students before design ideation and refinement begins. Approximately 1/3 of course content is skill development where exercises and “real life learning” takes place. During the year, students will delve into important design principles through 2 projects. Although both will be product or spatial related, the design context aims to solve 2 very different world problems (new learning will take place within each assessment).

Teacher in charge - Ms Jana Durdevic

### **Students in this course will be working towards**

19 credits that are internally assessed and 7 credits that are externally assessed

6 credits towards Level 1 Literacy

Course endorsement is possible in L2 Product and Spatial Design

This course leads to a university approved course.

## L2 DIGITAL TECHNOLOGY STUDIES (L2DTS)

*This course follows on from L1DTS and leads to L3DTS*

This course offers more advanced tuition in web design, programming and database design. (*Home internet, computer and 16Gb+ Flash Drive required*).

Students will learn how to: • Develop a conceptual design for an outcome using relevant conventions (*including web, coding, design elements and principals and Nieslen’s heuristics*) • Use advanced processes (*including project management tools and techniques*) to develop a digital media outcome (*web-HTML and CSS*) • Use feedback from end users/ stakeholders and information from testing procedures to improve their outcome • Address relevant implications • Use the process of iteration • Plan and create a computer program using Python, adhering to common conventions (*optional*) • Plan and create a relational database (*optional*) • Students will also look at advanced concepts in computer science. Topics include computer security, encryption, error control, complexity and tractability and AI (*3 hour external exam*) • Students also have the opportunity to complete an industry certification in either Microsoft or Adobe products.

Teacher in charge - Mrs Michelle Gallagher

### **Students in this course will be working towards**

14/16 credits that are internally assessed and 3 credits **that are** externally assessed

**Course endorsement** is possible in L2 Digital Technology

This course leads to a university approved course.

## L2 DESIGN AND TECHNOLOGY (L2TDT) λ

*This course follows on from L1TDT and leads to L3TDT, L3 TEN, L3 TWT*

This course is a University approved, Achievement Standard course in which students design and build individual projects based around items of furniture. It can include a range of materials, both hard and soft. Sustainability in design is a major focus of the course. Students in this course will be working towards.

Teacher in charge - Mr Nick Booth

### **Students in this course will be working towards**

16 credits that are internally assessed and 4 credits that are externally assessed

7 credits towards Level 1 Literacy

Course endorsement is possible in L2 Design and Technology.

This course leads to a university approved course.



## L2 ENGINEERING (L2TEN)

*This course follows on from L2TEN and leads to L3TEN*

This course is designed for students intending to take up an apprenticeship in any of the related fields. They will work towards following build instructions to complete an individual project. Students will need to demonstrate skills and knowledge in practical, written and graphic assignments.

Teacher in charge - Mr Matt Overington

**Students in this course will be working towards**

22 credits that are internally assessed and 0 credits that are externally assessed

Course endorsement is not possible in L2 Engineering

This course does not lead to a university approved course.

## L2 WOOD TECHNOLOGY (L2TWT)

*This course follows on from L1TWT and leads to L3TWT*

This is a full NCEA Unit Standard Technology course using wood-based products as a materials medium. Students will gain credits for success with design, brief development, individual production of a prototype and documentation of processes. An article of furniture will be made to take home.

Teacher in charge - Mr Jeff Evans

**Students in this course will be working towards**

24 credits that are internally assessed and 0 credits that are externally assessed

Course endorsement is not possible in L2 Wood Technology

This course does not lead to a university approved course.

## L2 CUISINE AND HOSPITALITY STUDIES (L2TCH)

*This course follows on from L1TCH and leads to L3TCH,*

This is a practical based course which includes units of learning recognised and linked with Polytechnics and Cuisine Institute Standards. This course is ideal for those seeking employment in this field or going on to advanced studies in Chef work, Hotel Management, Tourism or starting their own catering business.

Teacher in charge - Mrs Robyn Hunn

**Students in this course will be working towards**

20 credits that are internally assessed and 0 credits that are externally assessed

Course endorsement is not possible in L2 Hospitality without additional Achievement Standards.

Optional Achievement standards are available in Level 2.

This course does not lead to a university approved course.

## L3 DESIGN AND VISUAL COMMUNICATION (L3DVC) λ

*This course follows on from L2DVC*

A single, full year project from a student driven perspective. Brief, context and specifications are researched extensively by students before design ideation and refinement begins. After refinement students have the option to delve in authentic technical drawing or promote their work in a formal exhibition space. Students will use a range of modes and media to communicate design ideas. This includes the laser cutter, 3D printer, sketching tablets, CAD, model making and more.

Teacher in charge - Ms Jana Durdevic

**Students in this course will be working towards**

10 credits that are internally assessed and 6 credits that are externally assessed

Course endorsement is possible in L3 Product and Spatial Design

This course is university approved.

## L3 DIGITAL TECHNOLOGY STUDIES (L3DTS)

*This course follows on from L2DTS*

Students will learn how to: • Manage a project using project management tools including agile methodologies such as “Scrum” • Apply user experience methodologies to develop a design for a digital outcome, including competitive analysis, user personas, card sorts, wireframing and high fidelities • Use complex processes to develop a digital technology outcome (*web, app, VR etc*) synthesising information gained from planning, testing and trailing of components • Students will also study areas of computer science. Topics include formal languages network communication protocols and big data (*3 hour external exam*) • They also have the opportunity to complete an industry certification in either Microsoft Office or Adobe products and another external which is a reflective report over the year. (*Home internet, computer and 16Gb+ Flash Drive required.*)

Teacher in charge - Mrs Michelle Gallagher

### **Students in this course will be working towards**

16 credits that are internally assessed and 3 credits that are externally assessed

Course endorsement is possible in L3 Digital Technology

This course is university approved.

22 credits towards Level 1 Literacy

4B credits to UE literacy (R/W/B)

### L3 ENGINEERING (L3TEN)

*This course follows on from L2TEN*

This course is designed for students intending to take up an apprenticeship in any of the related fields. They will learn to use CNC, and work towards design and construction of various projects. Students will need to demonstrate skills and knowledge in practical, written and graphic assignments.

Teacher in charge - Mr Matt Overington

**Students in this course will be working towards**

20 credits that are internally assessed and 0 credits that are externally assessed

Course endorsement is not possible in L3 Engineering

This course is not university approved.

### L3 WOOD TECHNOLOGY (L3TWT)

*This course follows on from L2TWT*

This is a full NCEA Unit Standard Technology course using wood-based products as a materials medium. Students will gain credits for success with design, brief development, individual production of a prototype and documentation of processes. An article of furniture will be made to take home.

Teacher in charge - Mr Jeff Evans

**Students in this course will be working towards**

24 credits that are internally assessed and 0 credits that are externally assessed, with an optional further 16 internally assessed credits.

Course endorsement is not possible in L3 Wood Technology

This course is not university approved.

### L3 CUISINE AND HOSPITALITY STUDIES (L3TCH)

*This course follows on from L2TCH*

This is a practical based course which includes units of learning recognised and linked with Polytechnics and Cuisine Institute Standards. This course is ideal for those seeking employment in this field or going on to advanced studies in Chef work, Hotel Management, Tourism or starting their own catering business. Students will be expected to cater for functions.

Teacher in charge - Mrs Robyn Hunn

**Students in this course will be working towards**

29 credits that are internally assessed and 0 credits that are externally assessed

Course endorsement is not possible in L3 Hospitality

Course endorsement is not possible in L2 Hospitality without additional Achievement Standards.

Optional achievement standards are available in Level 2.

This course is not university approved.

# VISUAL ARTS

Head of Faculty – Mrs Liese Strong

Ext 893

[lstrong@lbc.school.nz](mailto:lstrong@lbc.school.nz)

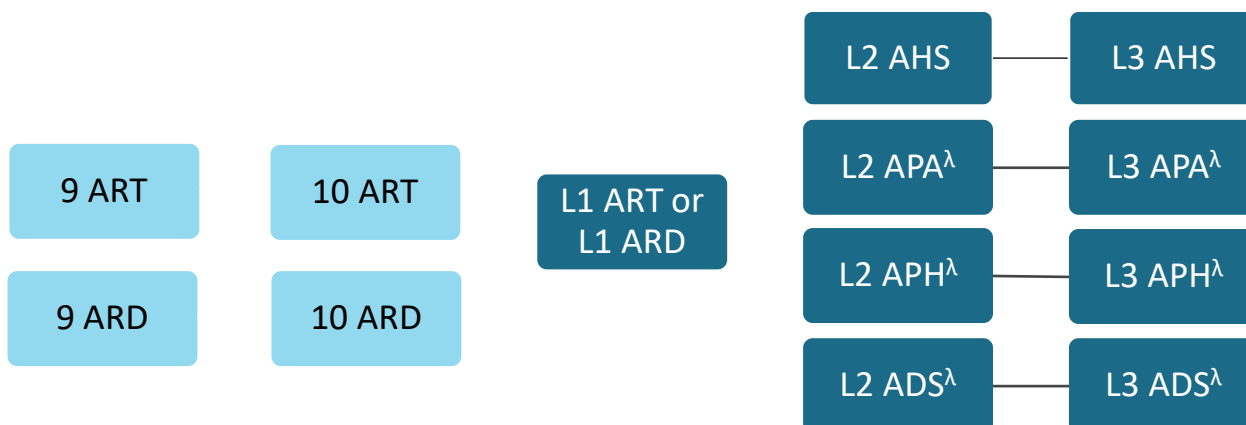

<sup>λ</sup> Portfolio subjects are indicated with this symbol  $\lambda$ . If choosing portfolio subjects, students are recommended to choose a maximum of two.

## YEAR 12 & 13 PORTFOLIO VISUAL ART COURSES\*

With permission of the Head of Faculty, students may take up to two practical Visual Art subjects i.e. any combination of two of the following: ADS, APA, or APH. In addition to this, students could also benefit from taking AHS which will further enhance their understanding of art and artists.

### Y9 ART (9ART)

*This course leads to 10ART, 10ARD*

This course is focused on developing a student's understanding of Art and ways to create it.

Students will develop technical skills in Drawing, Painting, Printmaking and Sculpture, whilst engaging in projects centralized around the theme 'Identity'. Students will deepen their understanding of how to portray ideas about themselves and will also develop the ability to think creatively, analyse art-making methods and apply these to their own art-making practice.

Teacher in charge - Mrs Liese Strong

### Y9 DIGITAL ART (9ARD)

*This course leads to 10ART, 10ARD*

This course is focused on developing a student's understanding of Digital Art and ways to create it.

Students will develop technical skills in Digital Photography, Digital Illustration and Stop-motion Animation, whilst engaging in projects centralized around the theme 'Planet Earth'. Students will deepen their understanding of how to portray ideas about social issues and will also develop the ability to think creatively, analyse art-making methods and apply these to their own art-making practice.

Teacher in charge - Mrs Liese Strong

### Y10 ART (10ART)

*This course leads to L1ART, L1ARD*

This course is focused on further developing a student's understanding of Art and ways to create it.

Students will develop technical skills in Drawing, Painting, Design Illustration and Printmaking, whilst engaging in two thematic projects. Students will deepen their understanding of how to portray both the physical and the imaginary, and will also develop the ability to think creatively, analyse art-making methods and apply these to their own art-making practice.

Teacher in charge - Mrs Liese Strong

## Y10 DIGITAL ART (10ARD)

*This course leads to L1ART, L1ARD*

This course is focused on further developing a student's understanding of Digital Art and ways to create it.

Students will develop technical skills in Digital Photography, Photographic manipulation, Digital Illustration, and Digital Animation using Adobe software; whilst engaging in projects centralized around the theme 'Alter Ego'. Students will deepen their understanding of how to portray both the physical and the imaginary, and will also develop the ability to think creatively, analyse art-making methods and apply these to their own art-making practice.

Teacher in charge - Mrs Liese Strong

## L1 ART (L1ART) λ

*This course follows on from 10ART, 10ARD and leads to L2ADS, L2APA, L2APH, L2AHS*

This innovative programme builds on the skills learnt in 10ART and 10ARD and is designed to extend a student's understanding of art-making techniques and creative processes. Students will produce work using traditional tactile art-making methods and there will also be opportunity for using digital methods.

Students will develop artistic responses to a broad theme and will learn to generate, develop and clarify their ideas using a variety of art-making methods. The focus of this year is on developing conceptual ideas and skills for future Art subject specialisation.

This course provides the essential foundations necessary for ongoing success in Senior Design, Painting and Photography.

Teacher in charge - Mrs Liese Strong

**Students in this course will be working towards**

10 credits that are internally assessed and 12 credits that are externally assessed

Course endorsement is possible in L1 Art

**Please note: students may only choose L1ART or L1ARD** (it is not possible to do both, due to the same Achievement Standards being on offer)

This course leads to a university approved course.

## L1 DIGITAL ART (L1ARD) Λ

*This course follows on from 10ART, 10ARD and leads to L2ADS, L2APA, L2APH, L2AHS*

This innovative programme builds on the skills learnt in 10ARD and 10ART and is designed to extend a student's understanding of art-making techniques and creative processes. Students will produce artwork using digital art-making methods and there will also be opportunity for using traditional tactile methods.

Students will develop artistic responses and interpretations to a broad theme and learn to generate, develop and clarify their ideas using a variety of art-making methods. The focus of this year is on developing conceptual ideas and skills for future Art subject specialisation.

This course provides the essential foundations necessary for ongoing success in Senior Design, Painting and Photography.

Teacher in charge - Mrs Liese Strong

**Students in this course will be working towards**

10 credits that are internally assessed and 12 credits that are externally assessed

Course endorsement is possible in L1 Digital Art

**Please note: students may only choose L1ARD or L1ART** (it is not possible to do both, due to the same Achievement Standards being on offer)

This course leads to a university approved course.

## L2 DESIGN (L2ADS) \* λ

*This course follows on from L1ART, L1ARD and leads to L3ADS*

This course builds on digital and multi-media skills and techniques that have been developed in Level 1 Art and Level 1 Digital Art. The focus is on Graphic Design, a process of visual communication and problem solving through the use of image, typography and other graphic elements. Students will develop skills in generating artwork through a range of processes and become proficient in digital image-making techniques using Adobe software. Illustration and animation options are also available to students.

Students will select their own theme to guide individual design scenarios and briefs. Students will also look to contemporary designers' ideas to inspire their own artworks.

Teacher in charge - Mrs Liese Strong

**Students in this course will be working towards**

8 credits that are internally assessed and 12 credits that are externally assessed

Course endorsement is possible in L2 Design

This course leads to a university approved course.

## L2 PAINTING (L2APA) \* λ

*This course follows on from L1ART, L1ARD and leads to L3APA*

This course builds on painting and multi-media skills and techniques that have been developed in Level 1 Art and Level 1 Digital Art. Students will select their own theme to guide their portfolio of work throughout the year. A conceptual approach is encouraged to stimulate 'out-of-the-box' thinking and experimental painting approaches. Students will also look to both traditional and contemporary artists' ideas to inspire their own artworks.

Teacher in charge - Mrs Liese Strong

**Students in this course will be working towards**

8 credits that are internally assessed and 12 credits that are externally assessed

Course endorsement is possible in L2 Painting

This course leads to a university approved course.

## L2 PHOTOGRAPHY (L2APH) \* λ

*This course follows on from L1ART, L1ARD and leads to L3APH*

This course builds on digital and conceptual skills that have been developed in Level 1 Art and Level 1 Digital Art. Students will develop technical skills on how to operate a digital SLR Camera, set-up for photoshoots, operate studio lighting, and refine imagery using post-production techniques in Adobe software. Students will select their own theme to guide their portfolio of work throughout the year. A conceptual approach is encouraged to stimulate 'out-of-the-box' thinking and experimental photography approaches. Students will also look to both traditional and contemporary photographers' ideas to inspire their own artworks.

Teacher in charge - Mrs Liese Strong

**Students in this course will be working towards**

8 credits that are internally assessed and 12 credits that are externally assessed

Course endorsement is possible in L2 Photography

This course leads to a university approved course.

## L2 ART HISTORY (L2AHS)

*This course follows leads to L3AHS*

Art History is a subject which allows you to understand the essence of society's ideas and priorities through unravelling how this is mirrored in the lives and artworks of artists.

The topic of study for this course is "Towards Modernism" which covers 19<sup>th</sup> Century Art in France. This was a time of dramatic social and political change in world history brought on by the Age of Enlightenment, French Revolutions and the Industrial Age. Art movements from Neo-Classicism to Post Impressionism are studied to unravel artists' ideas and Interpretation of reality in this modern and uncertain age.

Study in Art History is complementary to other subjects such as History and Classics and does not need to be taken in conjunction with Practical Art. It is however a valuable subject for Visual Art students and is especially beneficial to those students interested in studying Art, Design or Architecture at a Tertiary level.

Students choosing this course must show an ability to respond to teacher led research and written tasks in the classroom and the ability to work independently. This course requires strong analytical and literacy skills.

Teacher in charge - Mrs Liese Strong

**Students in this course will be working towards** 24 credits towards Level 1 Literacy  
12 credits that are internally assessed and 12 credits that are externally assessed 12R, 12B credits to UE literacy (R/W/B)

Course endorsement is possible in L2 Art History

This course leads to a university approved course.

## L3 DESIGN (L3ADS) \* λ

*This course follows on from L2ADS*

This course builds on the technical and conceptual skills developed in Level 2 Design and will further student expertise in this field. At this level students will be expected to choose their own themes, and study the work of contemporary designers to generate their own unique body of work.

Experimental technical skills with digital media are fostered as students explore a wide range of thematic ideas. Although print-based media is the most common area of study, illustration, animation and moving digital media are additional avenues for exploration linked to this course. Divergent conceptual thinking is encouraged and an eye for detail and precision is essential for success. There is a large external assessment component to this course which will require students to submit three portfolio panels of original work or a moving image portfolio.

This is a valuable subject for those students interested in studying Art, Design or Architecture at a Tertiary level.

Teacher in charge - Mrs Liese Strong

**Students in this course will be working towards**  
8 credits that are internally assessed and 14 credits that are externally assessed  
Course endorsement is possible in L3 Design

This course is university approved.

## L3 PAINTING (L3APA) \* λ

*This course follows on from L2APA*

This course builds on the technical and conceptual skills developed in Level 2 Painting and will further student expertise in this field. At this level students will be expected to choose their own themes and study the work of contemporary artists to generate their own individual programmes.

Experimental technical skills with wet and dry media are fostered as students explore a wide range of thematic ideas. Divergent conceptual thinking is encouraged and strong drawing skills are essential for success. There is a large external assessment component to this course which will require students to submit three portfolio panels of original work.

This is a valuable subject for those students interested in studying Art, Design or Architecture at a Tertiary level.

Teacher in charge - Mrs Liese Strong

### **Students in this course will be working towards**

8 credits that are internally assessed and 14 credits that are externally assessed

Course endorsement is possible in L3 Painting

This course is university approved.

## L3 PHOTOGRAPHY (L3APH) \* λ

*This course follows on from L2APH*

This course builds on the technical and conceptual skills developed in Level 2 Photography and is designed to further students' technical expertise in operating a digital SLR Camera. At this level students will be expected to choose their own themes and study the work of contemporary photographers to generate their own individual programmes.

Experimental technical skills with both the camera and post-production software are developed as students explore a wide range of thematic ideas. Divergent conceptual thinking is encouraged and is essential for success. There is a large external assessment component to this course which will require students to submit three portfolio panels of original work or a moving image portfolio.

This is a valuable subject for those students interested in studying Art, Design or Architecture at a Tertiary level.

Teacher in charge - Mrs Liese Strong

### **Students in this course will be working towards**

credits that are internally assessed and 14 credits that are externally assessed

Course endorsement is possible in L3 Photography

This course is university approved.



## L3 ART HISTORY (L3AHS)

*This course follows on from L2AHS*

Art History is a subject which allows you to understand the essence of society's ideas and priorities through unravelling how this is mirrored in the lives and artworks of artists.

The Topic of study is "Early Modernism" which takes place in the first half of the 20<sup>th</sup> Century, a period which covers both world wars and ground-breaking advances in science, technology and psychology. This was also a period of accelerated social, political, and philosophical change. Art movements from Cubism to Surrealism are studied to unravel artists' reinvention and interpretation of reality in this modern and uncertain age.

Study in Art History is complementary to other subjects such as History and Classics and does not need to be taken in conjunction with Practical Art. It is however a valuable subject for Visual Art students and is especially beneficial to those students interested in studying Art, Design or Architecture at a Tertiary level.

Students choosing this course must show an ability to respond to teacher led research and written tasks in the classroom and the ability to work independently. This course requires strong analytical and literacy skills.

Teacher in charge - Mrs Liese Strong

**Students in this course will be working towards**

24 credits towards Level 1 Literacy

12 credits that are internally assessed and 12 credits that are externally assessed

12R, 12B credits to UE literacy (R/W/B)

Course endorsement is possible in L3 Art History

This course is university approved.

---

[END OF DOCUMENT – CLICK TO RETURN TO CONTENTS](#)